

**eHealthBox v3.0
Consultation WS
Cookbook
Version 3.12**

This document is provided to you free, of charge, by the

eHealth platform

**Willebroekkaai 38 – 1000 Brussel
38, Quai de Willebroek – 1000 Bruxelles**

Anyone is free to distribute this document, referring to the URL source.

Table of contents

Contents

Table of contents	2
1. Document management	4
1.1 Document history.....	4
2. Introduction	5
2.1 Goal of the service	5
2.2 New in version 3.0.....	5
2.3 Goal of the document	5
2.4 eHealth platform document references	5
2.5 External document references.....	6
2.6 Service history.....	6
3. Support	7
3.1 Helpdesk eHealth platform	7
3.1.1 Certificates.....	7
3.1.2 For issues in production	7
3.1.3 For issues in acceptance.....	7
3.1.4 For business issues	7
3.2 Status	7
4. Global overview	8
5. Step-by-step	9
5.1 Technical requirements.....	9
5.1.1 Use of the eHealth SSO solution.....	9
5.1.2 Encryption.....	9
5.1.3 WS-I Basic Profile 1.1.....	9
5.1.4 Tracing	9
5.2 Process overview.....	10
5.2.1 Web Service - Web Service Definition Language (WSDL).....	10
5.3 eHealthBox Consultation WS	12
5.3.1 Lifetime of a message	12
5.3.2 Out-of-Office system	12
5.3.3 getBoxInfo Method	13
5.3.4 getMessagesList Method.....	16
5.3.5 getMessagesList Request	16
5.3.6 GetAllEhboxesMessagesList Method	20
5.3.7 getFullMessage Method	24
5.3.8 MoveMessage Method.....	27
5.3.9 DeleteMessage Method	30
5.3.10 getHistory Method	32
5.3.11 GetMessageAcknowledgmentsStatus Method	33



5.3.12	InsertOoO Method	36
5.3.13	DeleteOoO Method	39
5.3.14	GetOoOList Method	41
5.3.15	Used types	43
6.	Risks and security.....	57
6.1	SOAP with attachments	57
6.2	Security	57
6.2.1	Business security	57
6.2.2	Web service	57
6.2.3	Security policies to apply	58
7.	Test and release procedure.....	59
7.1	Procedure.....	59
7.1.1	Initiation	59
7.1.2	Development and test procedure	59
7.1.3	Release procedure	59
7.1.4	Operational follow-up	60
7.2	Test cases	60
8.	Error and failure messages.....	61
8.1	Error Element Status Codes	61
8.2	Consultation Response Status Codes	61
8.3	Soap Fault Error Code	62
8.3.1	Schema Validation Errors.....	65
8.3.2	Technical Errors	65
8.4	Error codes originating from the eHealth platform	66

To the attention of: "IT expert" willing to integrate this web service.

1. Document management

1.1 Document history

Version	Date	Author	Description of changes / remarks
3.0	06/05/2013	eHealth platform	eHealthBox v3.0 WS
3.1	05/02/2018	eHealth platform	New logo – modified links
3.2	30/04/2018	eHealth platform	Extract Annex
3.3	21/04/2020	eHealth platform	WS-I Org compliance
3.4	29/04/2020	eHealth platform	Anonymization of data examples
3.5	22/07/2021	eHealth platform	Precisions about GetMessageAcknowledgmentsStatus (section 5.3.11.1) + update document references
3.6	22/02/2022	eHealth platform	§ 5.3.1: Lifetime of a message
3.7	01/07/2022	eHealth platform	§ 3.2 Status (added) § 5.1.4 Tracing (updated)
3.8	20/07/2022	eHealth platform	§ 2.4 eHealth platform document references (updated)
3.9	16/02/2023	eHealth platform	§ 5.3.10 : Update GetHistory decommissioned
3.10	02/04/2023	eHealth platform	§ 8.2 : Precisions about error code 810
3.11	19/04/2023	eHealth platform	§ 5.3.6 : GetAllEhboxesMessagesList decommissioned
3.12	26/07/2023	eHealth platform	§ 5.3.15.17 : sender 12345678912 box (ACKs)

2. Introduction

2.1 Goal of the service

The eHealthBox Consultation WS allows an authenticated user to consult information about the content associated with his eHealthBox.

A user can get general information on his eHealthBox, a list of messages for a specific folder and the content of a specific message. He can also move a message to his inbox and handle his Out-of-Offices (OoO).

Fields indicated as 'obsolete' are old fields, still in use by some systems and kept for backward compatibility. They are out-of-date and must not be used by new partners, for they provide no 'extra' feature.

The size of a message is currently limited to 10MB. The global size of an eHealthBox is also limited to 10MB (including inbox and bin folder). Note that an encrypted message weighs more due to the encryption overhead.

2.2 New in version 3.0

- A new "Out-of-Office" system was implemented. It enables the sender to know if one of the recipients is absent and send his message to a substitute or substitutes in order to be treated. E.g.: physicians on holiday may want to ensure continuity of healthcare services for their patients. To do so, they can automatically transfer their messages to another colleague responsible during their holidays thanks to the "Out-of-Office" system.
- Three new methods were added: *InsertOoO* used to add an OoO, *DeleteOoO* used to delete an inserted OoO, *GetOoOList* used to get the list of inserted OoO.
- eHealthBoxes are now limited in size on inbox and trash bin folder. A new method *DeleteMessage* was added in order to be able to delete message from the trash bin folder or directly from the inbox.
- SOAP with Attachments (SwA) standard is now being used in place of MTOM.
- News and Document types were merged: News is now a special case of a document.
- *ContentSpecification* contains a *ContentType* element now, specifying the type of message. 2 new message types (error, acknowledgment) were added to the 2 existing (document, news).

2.3 Goal of the document

The eHealthBox Consultation WS allows an authenticated user to consult information about the content associated with his eHealthBox.

A user can get general information on his eHealthBox, a list of messages for a specific folder and the content of a specific message. He can also move a message to his inbox and handle his Out-of-Offices (OoO's).

Fields indicated as 'obsolete' are old fields, still in use by some systems and kept for backward compatibility. They are out-of-date and must not be used by new partners, for they provide no 'extra' feature.

The size of a message is currently limited to 10MB. The global size of an eHealthBox is also limited to 10MB (including inbox and bin folder). Note that an encrypted message weighs more due to the encryption overhead.

2.4 eHealth platform document references

On the portal of the eHealth platform, you can find all the referenced documents.¹. These versions, or any following ones, can be used for the eHealth platform service.

¹ www.ehealth.fgov.be/ehealthplatform

ID	Title	Version	Date	Author
1	Secure Token Service (STS)	1.6	25/01/2023	eHealth platform
2	End-to-End Encryption: bekende bestemming/Destinataire connu	2.9	18/07/2022	eHealth platform
3	eHealthBox Publication	3.13	26/07/2022	eHealth platform
4	eHealthBox – Supported Qualities	1.4	22/12/2022	eHealth platform
5	eHealth platform SSO eHealthBox	1.2	22/04/2020	eHealth platform
6	SOA – Error guide	1.0	10/06/2021	eHealth platform
7	Request test case template	3.0	22/02/2018	eHealth platform
8	WSDL		N.A.	eHealth platform

2.5 External document references

All documents can be found through the internet. They are available to the public, but not supported by the eHealth platform.

ID	Title	Date
1.	http://www.w3.org/TR/SOAP-attachments	11/12/2000
2.	http://www.ws-i.org/Profiles/AttachmentsProfile-1.0.html	20/04/2006
3.	http://ws-i.org/profiles/basic/1.1/swaref.xsd	NA
4.	http://docs.oasis-open.org/ws-sx/ws-securitypolicy/200702/	NA

2.6 Service history

This chapter contains the list of changes made to the service with respect to the previous version.

Previous version	Previous release date	changes
2.0 DEPRECATED	29/04/2012	Major changes: SOAP with Attachment, OoO system, DeleteMessage, MoveMessage, structured notification messages, performances.
1.0 DEPRECATED	03/02/2011	Major changes: Encryption, Multi-box, Publication Web Application, Consultation Web Application reviewed, general reliability ...

3. Support

3.1 Helpdesk eHealth platform

3.1.1 Certificates

In order to access the secured eHealth platform environment you have to obtain an eHealth platform certificate, used to identify the initiator of the request. In case you do not have one, please consult the chapter about the eHealth Certificates on the portal of the eHealth platform

- <https://www.ehealth.fgov.be/ehealthplatform/nl/ehealth-certificaten>
- <https://www.ehealth.fgov.be/ehealthplatform/fr/certificats-ehealth>

For technical issues regarding eHealth platform certificates

- Acceptance: acceptance-certificates@ehealth.fgov.be
- Production: support@ehealth.fgov.be

3.1.2 For issues in production

eHealth platform contact centre:

- Phone: 02 788 51 55 (on working days from 7 am till 8 pm)
- Mail: support@ehealth.fgov.be
- Contact Form :
 - <https://www.ehealth.fgov.be/ehealthplatform/nl/contact> (Dutch)
 - <https://www.ehealth.fgov.be/ehealthplatform/fr/contact> (French)

3.1.3 For issues in acceptance

Integration-support@ehealth.fgov.be

3.1.4 For business issues

- regarding an existing project: the project manager in charge of the application or service
- regarding a new project or other business issues: info@ehealth.fgov.be

3.2 Status

The website <https://status.ehealth.fgov.be> is the monitoring and information tool for the ICT functioning of the eHealth services that are partners of the Belgian eHealth system.

4. Global overview

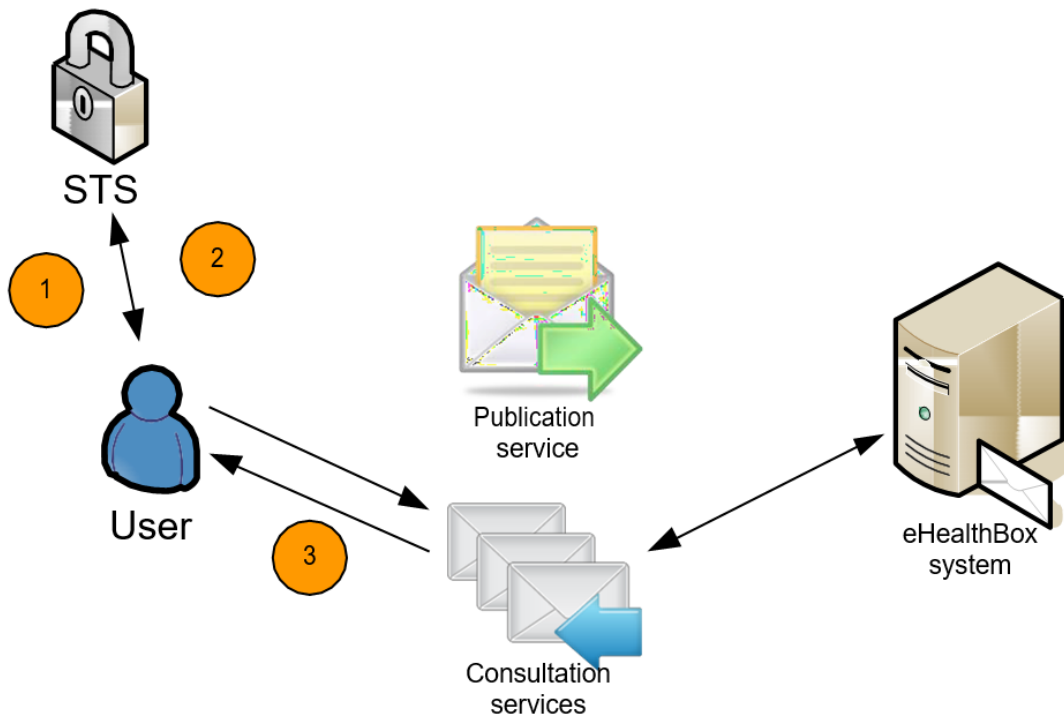

This global overview aims to show the different steps needed to use the Consultation WS.

- Step 1. The first required step for the user to use the Consultation WS is to contact the STS Service to acquire his proper token containing his data. (See 5.1.1)
- Step 2. With this token, the user can use the different "Consultation WS" to retrieve his message(s), manage his eHealthBox or get information on it.
- Step 3. Depending on the request of the user, the "Consultation WS" will provide him with an answer concerning his eHealthBox or one of his eHealthBoxes.
- Step 4. Finally, if the message was encrypted for the recipient, the client deciphers the message with his private key and the Crypto Library (please consult the "***ETEE for known recipient***")

In order to publish any message or reply, the user should use the eHealthBox publication process.

5. Step-by-step

5.1 Technical requirements

All the xml requests submitted to the WS must be encoded in the UTF-8 format.

5.1.1 Use of the eHealth SSO solution

This section specifies how the call to the Secure Token Service (STS) must be done in order to access the WS. You must precise several attributes in the request. The details on the identification attributes and the certification attributes can be found in the separate document eHealth *eHBox_SSO*.

To access the eHealth web service, the response token must contain “true” for the ‘boolean’ certification attribute.

If you obtain “false”, refer to the eHealth contact center to verify that the requested test cases were correctly configured.

5.1.2 Encryption

If an encrypted message was received, it has to be deciphered first. See Chapter 4 – Global Overview.

In order to decipher the content of a message and the various fields, you have to use the local stored private key and the Crypto Libraries. Each field must be deciphered separately (one at a time).

For more information about the use of the encryption libraries: please consult the Cookbook “*ETEE for known recipients*”.

If an encrypted message is received, ALL “*Encryptable*” fields contain (one and all) encrypted content. You can detect if the message has been encrypted with the element *IsEncrypted* in the responses from *GetMessagesList*, *GetAllEhboxesMessagesList* and *GetFullMessage*.

5.1.3 WS-I Basic Profile 1.1

Your request must be WS-I compliant (See Chap 2.4 - External Document Ref).

5.1.4 Tracing

To use this service, the request SHOULD contain the following two http header values (see RFC <https://datatracker.ietf.org/doc/html/rfc7231#section-5.5.3>):

1. User-Agent: information identifying the software product and underlying technical stack/platform. It MUST include the minimal identification information of the software such that the emergency contact (see below) can uniquely identify the component.
 - a. Pattern: {minimal software information}/{version} {minimal connector information}/{connector-package-version}
 - b. Regular expression for each subset (separated by a space) of the pattern: `[[a-zA-Z0-9-√]*√[0-9azA-Z-√].]*`
 - c. Examples:
User-Agent: myProduct/62.310.4 Technical/3.19.0
User-Agent: Topaz-XXXX/123.23.X freeconnector/XXXXX.XXX
2. From: email-address that can be used for emergency contact in case of an operational problem.
Examples:
From: info@mycompany.be



5.2 Process overview

5.2.1 Web Service - Web Service Definition Language (WSDL)

You will find all the technical information on website of the eHealth platform.



ehBoxConsultationPortType			
getBoxInfo			
input	body	GetBoxInfoRequest	↔
output	body	GetBoxInfoResponse	↔
BusinessError	fault	BusinessError	↔
SystemError	fault	SystemError	↔
getMessagesList			
input	body	GetMessagesListRequest	↔
output	body	GetMessagesListResponse	↔
BusinessError	fault	BusinessError	↔
SystemError	fault	SystemError	↔
getAllEhboxesMessagesList			
input	body	GetAllEhboxesMessagesListRequest	↔
output	body	GetAllEhboxesMessagesListResponse	↔
BusinessError	fault	BusinessError	↔
SystemError	fault	SystemError	↔
getFullMessage			
input	body	GetFullMessageRequest	↔
output	body	GetFullMessageResponse	↔
BusinessError	fault	BusinessError	↔
SystemError	fault	SystemError	↔
moveMessage			
input	body	MoveMessageRequest	↔
output	body	MoveMessageResponse	↔
BusinessError	fault	BusinessError	↔
SystemError	fault	SystemError	↔
deleteMessage			
input	body	DeleteMessageRequest	↔
output	body	DeleteMessageResponse	↔
BusinessError	fault	BusinessError	↔
SystemError	fault	SystemError	↔
getMessageHistory			
input	body	GetHistoryRequest	↔
output	body	GetHistoryResponse	↔
BusinessError	fault	BusinessError	↔
SystemError	fault	SystemError	↔
getMessageAcknowledgmentsStatus			
input	body	GetMessageAcknowledgmentsStatusRequest	↔
output	body	GetMessageAcknowledgmentsStatusResponse	↔
BusinessError	fault	BusinessError	↔
SystemError	fault	SystemError	↔
insertOoO			
input	body	InsertOoORequest	↔
output	body	InsertOoOResponse	↔
BusinessError	fault	BusinessError	↔
SystemError	fault	SystemError	↔
deleteOoO			
input	body	DeleteOoORequest	↔
output	body	DeleteOoOResponse	↔
BusinessError	fault	BusinessError	↔
SystemError	fault	SystemError	↔
getOoOList			
input	body	GetOoOListRequest	↔
output	body	GetOoOListResponse	↔
BusinessError	fault	BusinessError	↔
SystemError	fault	SystemError	↔



The important sections of the WSDL of the Consultation WS are:

- The applicable **Policies**, which cover the **security** aspects.
- The different methods: **getBoxInfo**, **getMessagesList**, **GetAllEhboxesMessagesList**, **getFullMessage**, **moveMessage**, **getMessageHistory**, **getMessageAcknowledgmentsStatus**, **InsertOoO**, **DeleteOoO**, **GetOoOList**.
- The types that are used by the methods.
- The fault messages are also defined for each method.

5.3 eHealthBox Consultation WS

5.3.1 Lifetime of a message

A message will automatically be deleted when:

- the message is in the folder "IN" for more than one year. The exact date can be retrieved in the key "expirationDate".
- the message is in the folder "SENT" for more than 3 days and does no longer exist in the folder "INBOX", "BININBOX" or "STANDBY" of any box or the message is in the folder "SENT" for more than one year.
- the message is in the folder "BININBOX " for more than 3 months and has already been read. The exact date can be calculated by adding three months to the PublicationDate. Unread messages, older than three months will remain in the folder until they are read or the expirationDate has passed.
- the message is in the folder "BINSENTBOX" for more than 3 months. The exact date can be calculated by adding three months to the PublicationDate.
- the message is of type 'ACKNOWLEDGMENT' (see ContentType) and older than 30 days.

5.3.2 Out-of-Office system

5.3.2.1 Introduction

This system enables the sender to know whether one of the recipients is absent and send his message to a substitute or substitutes to be treated. For example, physicians on holiday may want to ensure continuity of healthcare services for their patients. They can automatically transfer their messages to another colleague responsible during their holidays thanks to the "Out-of-Office" system. (Abbreviation: OoO)

5.3.2.2 Out-of-Office restrictions

- **A person cannot be defined as a substitute if he is already absent for this period (or part of the period).**
- It is however possible to introduce an OoO while being a substitute for someone else.
- A person may be substitute for several other persons.
- The absentee and his substitutes are persons, not organizations.
- A person is identified by his ID and his quality.
- There may be maximum five substitutes per OoO.
- A maximum of TEN periods OoO may exist per eHealthBox.
- **OoO periods may not overlap.**
- A period may not go beyond J + 1Year.
- A period can last up to 1 Year.
- The end date is mandatory.

A WS request contains one period and a maximum of five substitutes may be specified for that period. The OoO activates automatically when the time is reached.



5.3.3 getBoxInfo Method

The *getBoxInfo* method allows an authenticated user to receive general information about his mailbox: the current used size of your mailbox, the maximum allowed size of your mailbox, and the number of messages, which could not be received because the mailbox was full. These messages are still waiting to be put in your mailbox. You need to clean your mailbox until the current size is lower than the max size. The messages will then enter into your mailbox.

5.3.3.1 getBoxInfo Request

You can optionally request information of another of your mailboxes by specifying it via BoxId,

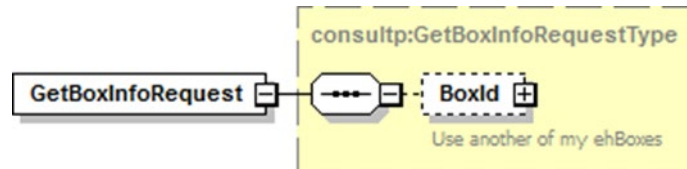

Field name	Description
BoxId	If the client wants to use one of his other eHealthBoxes, he can specify it here (see section 5.3.15.3). This avoids the client having to re-authenticate himself each time.

5.3.3.2 *getBoxInfo Response*

The response contains a success status code and general information on the eHealthBox as explained below. The *BoxId* element enables you to discover information on the current eHealthBox if you currently do not have any. Attention should be paid to *NbrMessagesInStandBy* larger than zero and if *CurrentSize* > *MaxSize*.

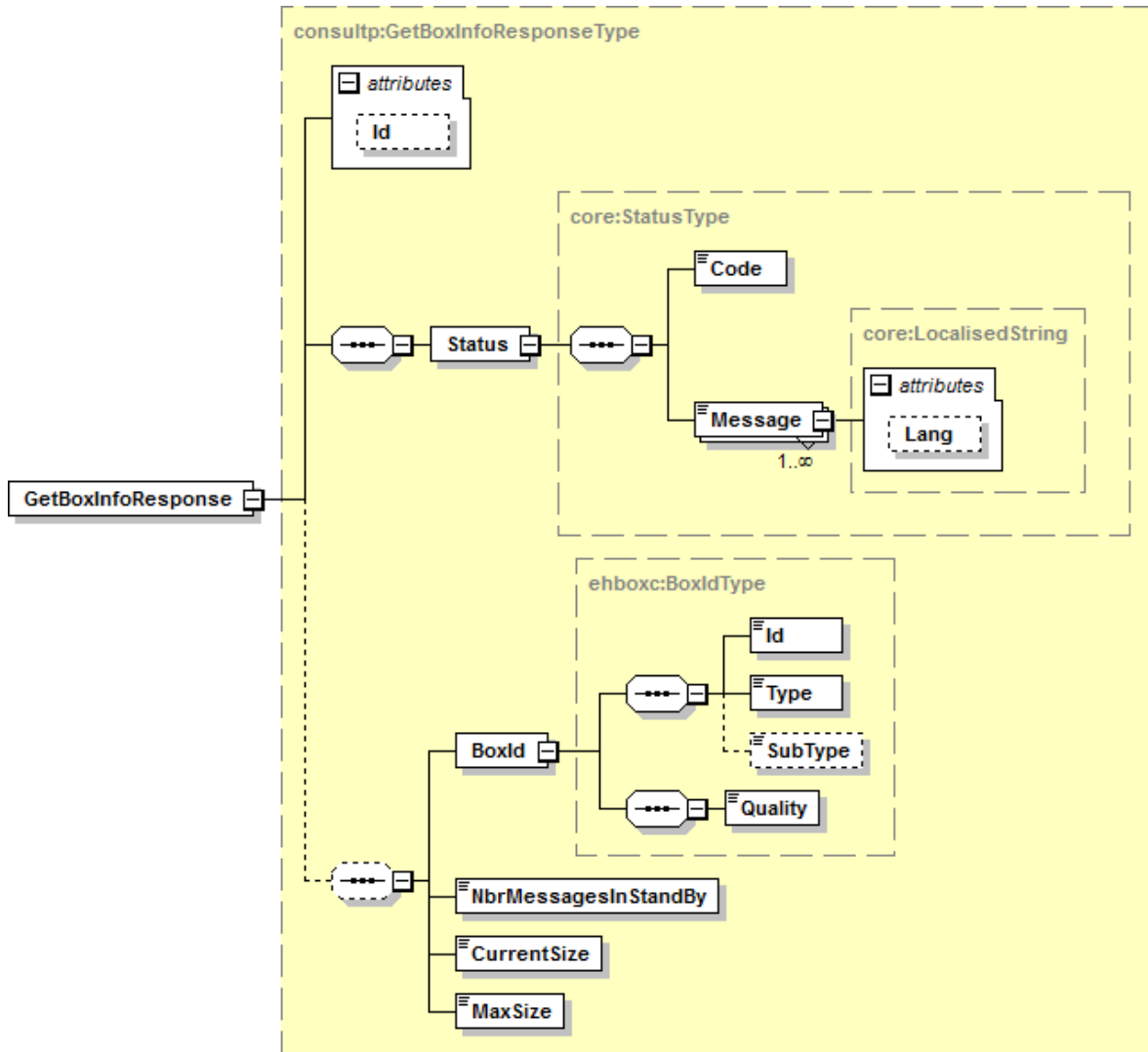

Field name	Description
Id	The ticket number (<i>Id</i>) attributed to the exchange request/response by the eHealth platform is used to identify the session.
Status	The <i>Status</i> block contains a code and a message. If no error has occurred during transaction, the <i>Code</i> will be '100' and the <i>Message</i> 'SUCCESS'. Otherwise: In case of a business error: The <i>Code</i> is an error code that unequivocally identifies the problem (see Chapter 7 for the possible values). The <i>Message</i> will be a description of the error. Each <i>Message</i> has a <i>Lang</i> (language) characteristic: "FR": French

	"NL": Dutch "EN": English "DE": German "NA": Not applicable
	In case of technical errors, you will receive a Soap Fault message (see Chapter 8).
BoxId	The identification number (<i>Id</i>) and the Type of the eHealthBox are provided. If applicable, the <i>Subtype</i> is also returned. The <i>Quality</i> of the owner from the eHealthBox
NbrMessagesInStandBy	The number of messages in standby because the eHealthBox is full. To consult these messages, the user has to delete some of the other ones.
CurrentSize	The current size of the eHealthBox expressed in bytes.
MaxSize	The maximum size of the eHealthBox expressed in bytes.

5.3.3.3 Example

The following example does not contain the SAML assertion.

Request:

```

<soapenv:Envelope
  xmlns:soapenv="http://schemas.xmlsoap.org/soap/envelope/"
  xmlns:urn="urn:be:fgov:ehealth:ehbox:consultation:protocol:v3">
  <soapenv:Header/>
  <soapenv:Body>
    <urn:GetBoxInfoRequest/>
  </soapenv:Body>
</soapenv:Envelope>

```

Response:

```

<S:Envelope xmlns:S="http://schemas.xmlsoap.org/soap/envelope/">
  <S:Body>
    <ns3:GetBoxInfoResponse
      xmlns:ns2="urn:be:fgov:ehealth:errors:service:v1"
      xmlns:ns3="urn:be:fgov:ehealth:ehbox:consultation:protocol:v3">
      <Status>
        <Code>100</Code>
        <Message Lang="EN">SUCCESS</Message>
      </Status>
      <BoxId>
        <Id>99999999964</Id>
        <Type>INSS</Type>
        <Quality>DOCTOR</Quality>
      </BoxId>
      <NbrMessagesInStandBy>0</NbrMessagesInStandBy>
      <CurrentSize>58</CurrentSize>
    </ns3:GetBoxInfoResponse>
  </S:Body>
</S:Envelope>

```



```

        <MaxSize>10485760</MaxSize>
    </ns3:GetBoxInfoResponse>
</S:Body>
</S:Envelope>

```

5.3.4 getMessagesList Method

The *getMessagesList* method provides a list of messages for a specific folder of your eHealthBox listed in order by date (most recent first, index "1"). A consequence could be that if a new message arrives between two consecutive queries, a message will be shown two times (message "1" becomes "2", "2" becomes "3", etc.). E.g. if you requested the messages between "1" and "100" and then the messages between "101" and "200", then the message "100" would be the same as message "101".

The content of the messages is not returned yet by this method but it returns a list with all the information needed to treat, filter, sort the messages. The sender, recipient, title message, publication date, message size, custom metas are all displayed for example.

5.3.5 getMessagesList Request

You can optionally request information from another of your mailboxes by specifying it via *BoxId*. This method can only return 100 messages at a time; consequently, you must use it multiple times if necessary.

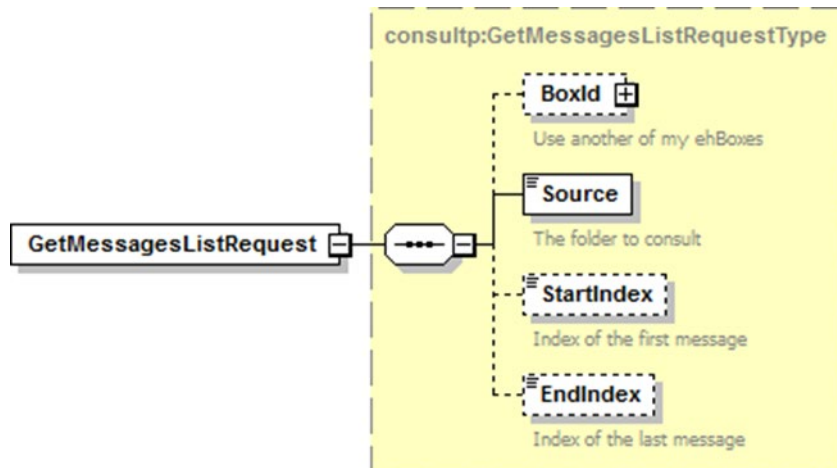

Field name	Description
BoxId	If the client wants to use one of his other eHealthBoxes, he can specify it here (see section 5.3.15.3). This avoids the client having to re-authenticate himself each time.
Source	You can mention the folder specific to your request via the <i>Source</i> parameter. The possible values are: "INBOX" for the inbox folder. "SENTBOX" for the sent box folder. "BININBOX" for messages moved from the inbox folder. "BINSENTBOX" for messages moved from the sent box folder.
StartIndex	Index of the first message (minimum 1).
EndIndex	Index of the last message (minimum 1). A maximum of 100 messages can be returned at once. EndIndex < StartIndex + 100



5.3.5.1 *getMessageList Response*

The response contains a success status code and as many *Message* elements as there are messages in the considered eHealthBox. Each element contains all the necessary information to treat the message without downloading each individual message.

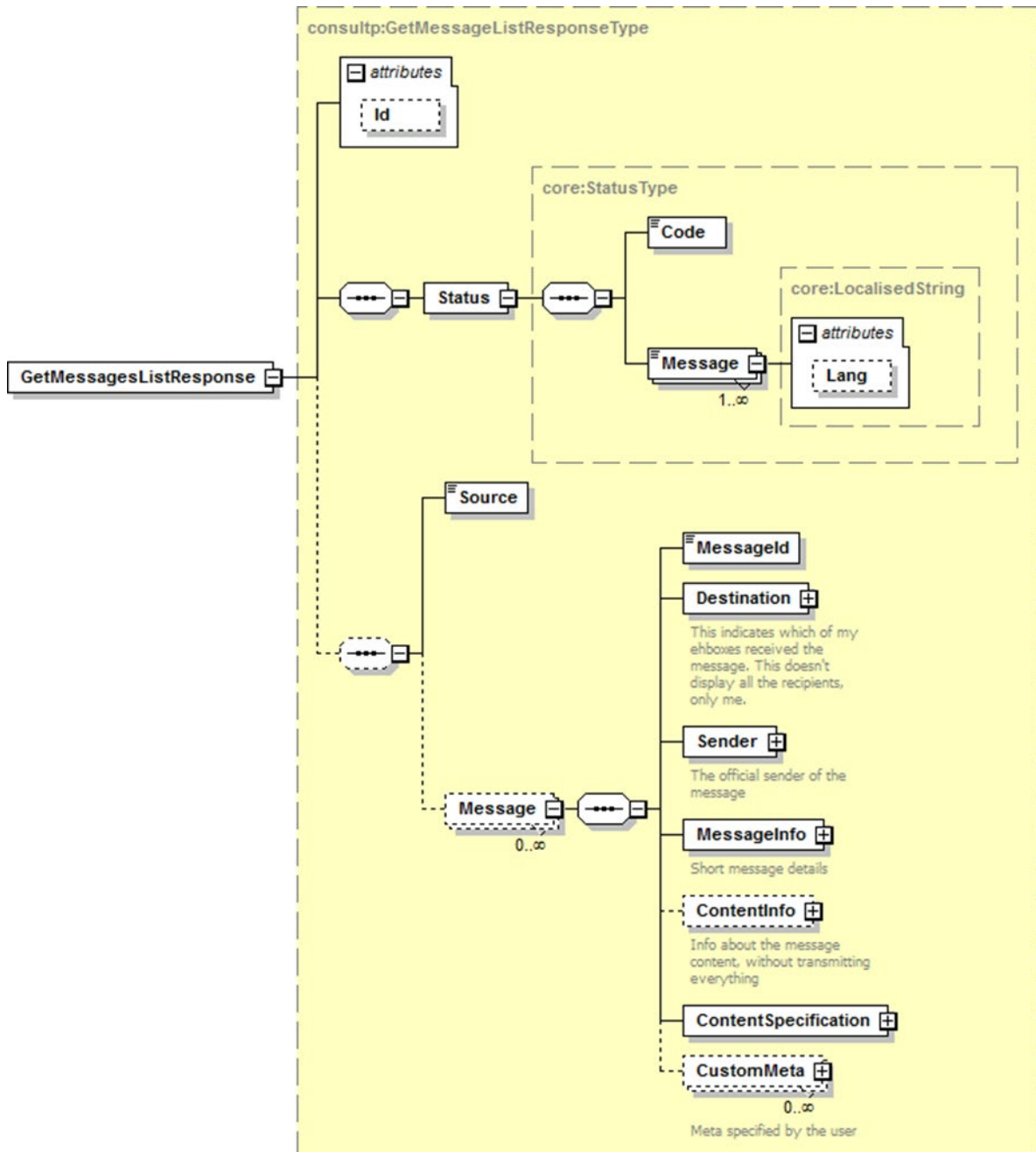

Field name	Description
Id	The ticket number (<i>Id</i>), attributed to the exchange request/response by the eHealth platform and used to identify the eHealth platform session.

Status	<p>The <i>Status</i> block contains a code and a message. If no error has occurred during the transaction, the <i>Code</i> will be '100' and the <i>Message</i> 'SUCCESS'. Otherwise: In case of a business error:</p> <ul style="list-style-type: none"> • The <i>Code</i> is an error code that unequivocally identifies the problem (see Chapter 7 for the possible values).
	<ul style="list-style-type: none"> • The <i>Message</i> will be a description of the error. Each <i>Message</i> has a <i>Lang</i>(language) characteristic : <ul style="list-style-type: none"> - "FR": French - "NL": Dutch - "EN": English - "DE": German - "NA": Not applicable <p>In case of technical errors, you will receive a Soap Fault message (see Chapter 8).</p>
Source	<p>You can define the folder specific to your request via the <i>Source</i> parameter. The possible values are:</p> <ul style="list-style-type: none"> • "INBOX" for the inbox folder. • "SENTBOX" for the sent box folder. • "BININBOX" for messages moved from the inbox folder. • "BINSENTBOX" for messages moved from the sent box folder.
Message	<p>0-to-more <i>Message</i> tag(s) describe(s) the eHealthBox <i>Message</i>(s). Each of them is defined by the following:</p> <ul style="list-style-type: none"> • The <i>MessageId</i> that represents a unique message identification generated by the system and returned during publication and when calling the <i>getMessagesList</i>. String of 13 digits. • The <i>Destination</i> of the <i>Message</i> (see section 5.3.15.16) • The <i>Sender</i> of the <i>Message</i> • The <i>MessageInfo</i> that contains additional information about the <i>Message</i> such as publication date, size ... (see section 5.3.15.14). • The <i>ContentInfo</i> of the <i>Message</i> such as title, mime type ... (see section 5.3.15.6) • The <i>ContentSpecification</i> of the <i>Message</i> that contains information such as importance ... (see section 5.3.15.7). • The <i>CustomMeta</i> of the <i>Message</i> that contains free <i>Meta</i> data specified by the user (see section 5.3.15.8)

5.3.5.2 Example

The following example does not contain the SAML assertion.

Request

```
<soapenv:Envelope
xmlns:soapenv="http://schemas.xmlsoap.org/soap/envelope/"
xmlns:urn="urn:be:fgov:ehealth:ehbox:consultation:protocol:v3">
  <soapenv:Header/>
  <soapenv:Body>
    <urn:GetMessagesListRequest>
      <Source>INBOX</Source>
    </urn:GetMessagesListRequest>
  </soapenv:Body>
</soapenv:Envelope>
```



```

        <StartIndex>1</StartIndex>
        <EndIndex>100</EndIndex>
    </urn:GetMessagesListRequest>
</soapenv:Body>
</soapenv:Envelope>

```

Response:

```

<S:Envelope xmlns:S="http://schemas.xmlsoap.org/soap/envelope/">
  <S:Body>
    <ns4:GetMessagesListResponse
xmlns:ns2="urn:be:fgov:ehealth:errors:service:v1"
xmlns:ns4="urn:be:fgov:ehealth:ehbox:consultation:protocol:v3">
      <Status>
        <Code>100</Code>
        <Message Lang="EN">SUCCESS</Message>
      </Status>
      <Source>INBOX</Source>
      <Message>
        <MessageId>9Y0002LKM100K</MessageId>
        <Destination>
          <Id>12345678910</Id>
          <Type>INSS</Type>
          <Quality>DOCTOR</Quality>
        </Destination>
        <Sender>
          <Id>71000000</Id>
          <Type>NIHII</Type>
          <Quality>HOSPITAL</Quality>
          <Name>Doe</Name>
          <FirstName>John</FirstName>
        </Sender>
        <MessageInfo>
          <PublicationDate>2011-06-28+02:00</PublicationDate>
          <ExpirationDate>2011-12-31+01:00</ExpirationDate>
          <Size>46</Size>
        </MessageInfo>
        <ContentInfo>
          <EncryptableINSSPatient>OTgwNTMwNDU3NDYyMQ0K</EncryptableINSSPatient>
          <ContentType>NEWS</ContentType>
          <Title>News in eHealthBox</Title>
          <MimeType>text/plain</MimeType>
          <HasFreeInformations>true</HasFreeInformations>
          <HasAnnex>>false</HasAnnex>
        </ContentInfo>
        <ContentSpecification>
          <IsImportant>>false</IsImportant>

```



```

        <IsEncrypted>>false</IsEncrypted>
    </ContentSpecification>
</Message>
</ns4:GetMessagesListResponse>
</S:Body>
</S:Envelope>

```

5.3.6 GetAllEhboxesMessagesList Method

WARNING : This method is decommissioned. It can in fact no longer be used since the HC (High Capacity) technical version of eHealthBox. You must use the `GetMessagesList` method on each box.

The `GetAllEhboxesMessagesList` method provides a list of all the messages from all the eHealthBoxes of a user (personal and enterprise eHealthBoxes) for a specific folder. This method repeatedly calls upon the `GetMessagesList` method for all known eHealthBoxes of the currently connected user.

5.3.6.1 GetAllEhboxesMessagesList Request

This method can only return 100 messages at a time; consequently, you must call upon it multiple times if necessary.

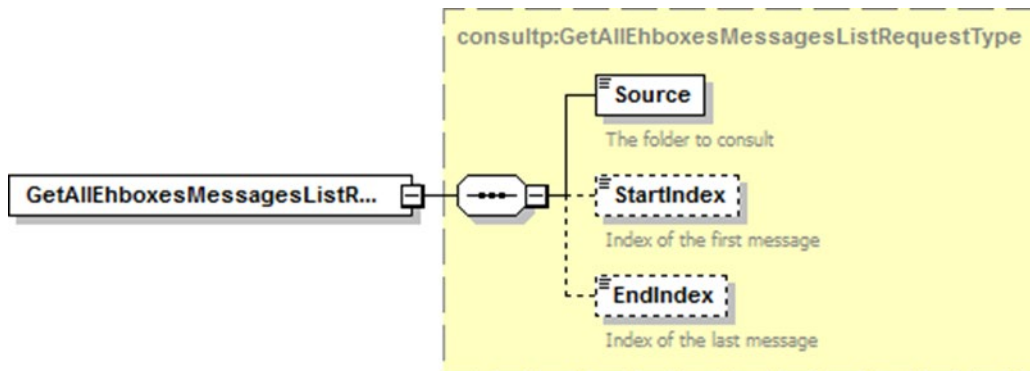

Field name	Description
Source	You can define the folder specific to your request via the <i>Source</i> parameter. The possible values are: <ul style="list-style-type: none"> • "INBOX" for the inbox folder. • "SENTBOX" for the sent box folder. • "BININBOX" for messages moved from the inbox folder. • "BINSENTBOX" for messages moved from the sent box folder.
StartIndex	Index of the first message (minimum 1).
EndIndex	Index of the last message (minimum 1). A maximum of 100 messages can be returned at a time. $EndIndex < StartIndex + 100$

5.3.6.2 GetAllEhboxesMessagesList Respons

The response contains a success status code and as many *Message* elements as there are messages in all the eHealthBoxes of the currently connected user (personal and enterprise eHealthBoxes). Each element contains all necessary information to treat the message without downloading each individual message. You can identify eHealthBox which received the message via the *Destination* element.

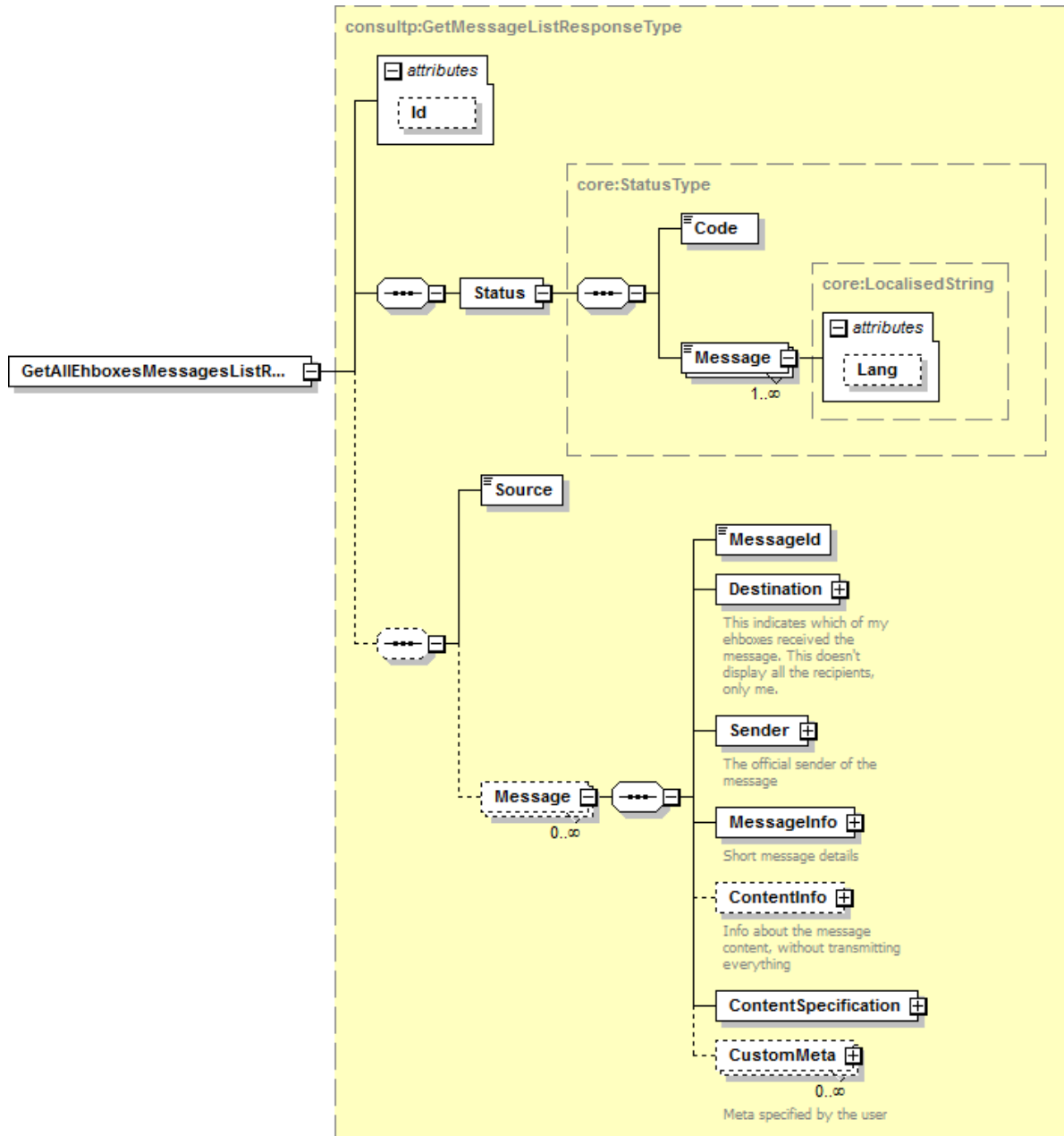

Field name	Description
Id	The ticket number (<i>Id</i>), attributed to the exchange request/response by the eHealth platform and used to identify the eHealth platform session.

Status	<p>The <i>Status</i> block contains a code and a message. If no error has occurred during the transaction, the <i>Code</i> will be '100' and the <i>Message</i> 'SUCCESS'. Otherwise:</p> <p>In case of a business error:</p> <ul style="list-style-type: none"> • The <i>Code</i> is an error code that unequivocally identifies the problem (see Chapter 7 for the possible values). • The <i>Message</i> will be a description of the error. Each Message has a <i>Lang</i> (language) characteristic : <ul style="list-style-type: none"> - "FR": French - "NL": Dutch - "EN": English - "DE": German - "NA": Not applicable <p>In case of technical errors, you will receive a SOAP Fault message (see Chapter 8).</p>
Source	<p>You can specify the folder concerned by your request via the <i>Source</i> parameter. The possible values are:</p> <ul style="list-style-type: none"> • "INBOX" for the inbox folder. • "SENTBOX" for the sent box folder. • "BININBOX" for messages moved from the inbox folder. • "BINSENTBOX" for messages moved from the sent box folder.
Message	<p>0-to-more Message tag(s) describe(s) the eHealthBox Message(s). Each of them is defined with the following:</p> <ul style="list-style-type: none"> • The <i>MessageId</i> that represents a unique message identification generated by the system and returned during the publication and when calling upon the <i>getMessagesList</i>. • The <i>Destination</i> of the Message (see section 5.3.15.16). • The <i>Sender</i> of the Message. • The <i>MessageInfo</i> that contains additional information about the Message such as publication date, size ... (see section 5.3.15.14). • The <i>ContentInfo</i> of the Message such as title, mime type ... (see section 5.3.15.6). • The <i>ContentSpecification</i> of the Message that contains information such as importance ... (see section 5.3.15.7). • The <i>CustomMeta</i> of the Message that contains free Meta data specified by the user (see section 5.3.15.8)

5.3.6.3 Example

The following example does not contain the SAML assertion.

Request:

```
<soapenv:Envelope
xmlns:soapenv="http://schemas.xmlsoap.org/soap/envelope/"
xmlns:urn="urn:be:fgov:ehhealth:ehbox:consultation:protocol:v3">
  <soapenv:Header/>
  <soapenv:Body>
    <urn:GetAllEhboxesMessagesListRequest>
      <Source>INBOX</Source>
    </urn:GetAllEhboxesMessagesListRequest>
  </soapenv:Body>
</soapenv:Envelope>
```



```

        <StartIndex>1</StartIndex>
        <EndIndex>100</EndIndex>
    </urn:GetAllEhboxesMessagesListRequest>
</soapenv:Body>
</soapenv:Envelope>

```

Response:

```

<S:Envelope xmlns:S="http://schemas.xmlsoap.org/soap/envelope/">
  <S:Body>
    <ns4:GetAllEhboxesMessagesListResponse
xmlns:ns2="urn:be:fgov:ehealth:errors:service:v1"
xmlns:ns4="urn:be:fgov:ehealth:ehbox:consultation:protocol:v3">
      <Status>
        <Code>100</Code>
        <Message Lang="EN">SUCCESS</Message>
      </Status>
      <Source>INBOX</Source>
      <Message>
        <MessageId>9Y0002LVHU003</MessageId>
        <Destination>
          <Id>99999999965</Id>
          <Type>INSS</Type>
          <Quality>DOCTOR</Quality>
        </Destination>
        <Sender>
          <Id>99999999964</Id>
          <Type>INSS</Type>
          <Quality>DOCTOR</Quality>
          <Name>Doe</Name>
          <FirstName>Jonh</FirstName>
        </Sender>
        <MessageInfo>
          <PublicationDate>2011-10-12+02:00</PublicationDate>
          <ExpirationDate>2011-10-17+02:00</ExpirationDate>
          <Size>0</Size>
        </MessageInfo>
        <ContentInfo>
          <EncryptableINSSPatient/>
          <ContentType>NEWS</ContentType>
          <Title>test title</Title>
          <MimeType>application/octet-stream</MimeType>
          <HasFreeInformations>>false</HasFreeInformations>
          <HasAnnex>>false</HasAnnex>
        </ContentInfo>
        <ContentSpecification>
          <IsImportant>>false</IsImportant>
          <IsEncrypted>>false</IsEncrypted>
        </ContentSpecification>

```



```

        </Message>
    </ns4:GetAllEhboxesMessagesListResponse>
</S:Body>
</S:Envelope>

```

5.3.7 getFullMessage Method

The *getFullMessage* method is used to get the corresponding complete message and its content to a provided *MessageId*.

5.3.7.1 getFullMessage Request

You can optionally request a message from another of your mailboxes by specifying it via *BoxId*.

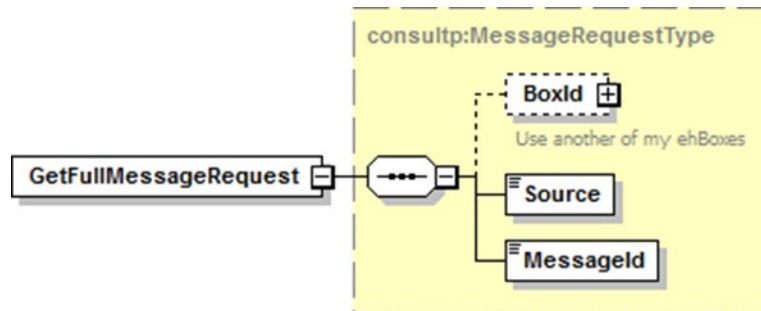

Field name	Description
BoxId	If the client wants to use another of his eHealthBoxes, he can specify it here (see section 5.3.15.3). This avoids the client having to re-authenticate himself each time.
Source	You can specify the folder specific to your request via the <i>Source</i> parameter. The possible values are: <ul style="list-style-type: none"> • "INBOX" for the inbox folder. • "SENTBOX" for the sent box folder.
MessageId	The <i>MessageId</i> is a unique message identification generated by the system and returned during the publication and when calling upon the <code>getMessagesList</code> . String of 13 digits.

5.3.7.2 *getFullMessage Response*

The response contains the same information as already returned by *GetMessagesList* plus the *Message* content in the element *Message*.

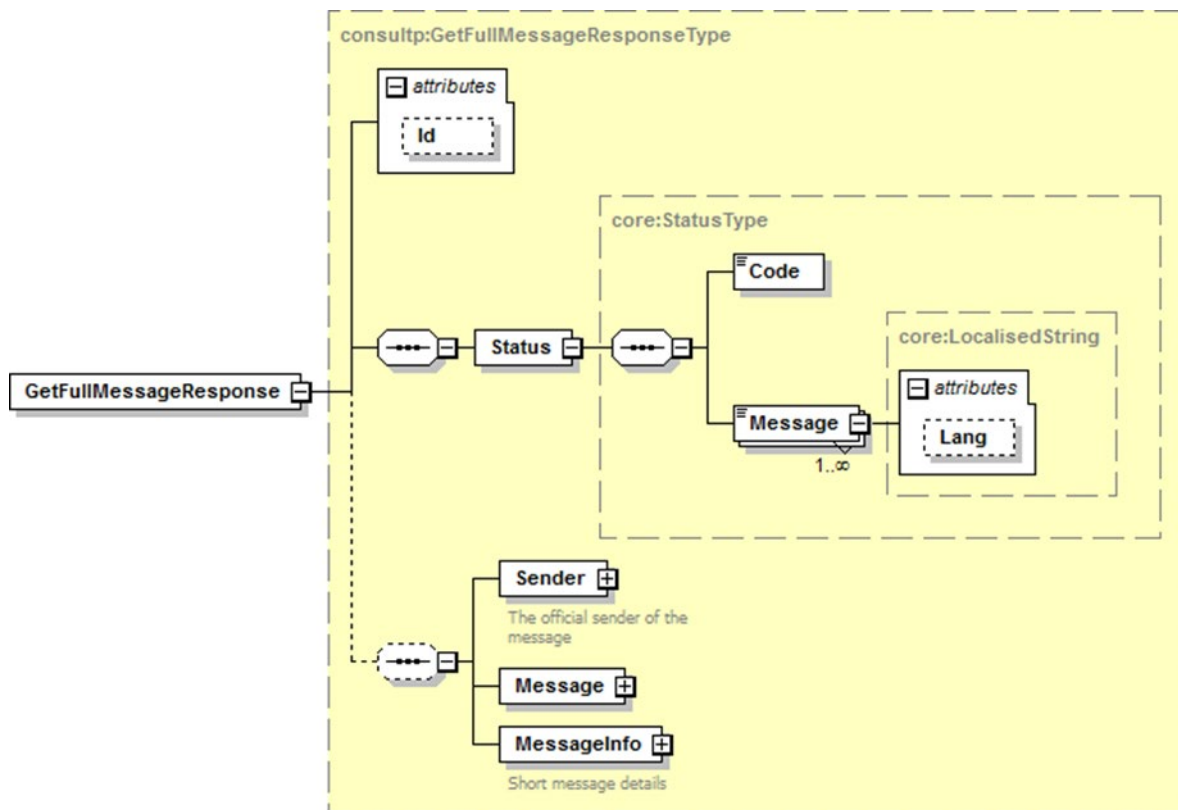

Field name	Description
Id	The ticket number (<i>Id</i>) attributed to the exchange request/response by the eHealth platform is used to identify the eHealth platform session.
Status	<p>The <i>Status</i> block contains a code and a message. If no error has occurred during the transaction, the <i>Code</i> will be '100' and the <i>Message</i> 'SUCCESS'. Otherwise:</p> <p>In case of a business error:</p> <ul style="list-style-type: none"> • The <i>Code</i> is an error code that unequivocally identifies the problem (see Chapter 7 for the possible values). • The <i>Message</i> will be a description of the error. Each <i>Message</i> has a <i>Lang</i> (language) characteristic : <ul style="list-style-type: none"> - "FR": French - "NL": Dutch - "EN": English - "DE": German - "NA": Not applicable <p>In case of technical errors, you will receive a Soap Fault message (see Chapter 8).</p>
Sender	The <i>Sender</i> of the Message

Message	The <i>Message</i> itself (see section 5.3.15.13)
MessageInfo	Additional information about the Message (see section 5.3.15.14)

5.3.7.3 Example

The following example does not contain the SAML assertion.

Request:

```
<soapenv:Envelope
  xmlns:soapenv="http://schemas.xmlsoap.org/soap/envelope/"
  xmlns:urn="urn:be:fgov:ehhealth:ehbox:consultation:protocol:v3">
  <soapenv:Header/>
  <soapenv:Body>
    <urn:GetFullMessageRequest>
      <Source>INBOX</Source>
      <MessageId>9Y0002LKLP004</MessageId>
    </urn:GetFullMessageRequest>
  </soapenv:Body>
</soapenv:Envelope>
```

Response:

```
<S:Envelope xmlns:S="http://schemas.xmlsoap.org/soap/envelope/">
  <S:Body>
    <ns4:GetFullMessageResponse
      xmlns:ns2="urn:be:fgov:ehhealth:errors:service:v1"
      xmlns:ns4="urn:be:fgov:ehhealth:ehbox:consultation:protocol:v3">
      <Status>
        <Code>100</Code>
        <Message Lang="EN">SUCCESS</Message>
      </Status>
      <Sender>
        <Id>71000000</Id>
        <Type>NIHII</Type>
        <Quality>HOSPITAL</Quality>
        <Name>Doe</Name>
        <FirstName>John</FirstName>
      </Sender>
      <Message MessageId="9Y0002LKLP004">
        <PublicationId>InitialDoc</PublicationId>
        <DestinationContext>
          <Id>99999999964</Id>
          <Type>INSS</Type>
          <Quality>DOCTOR</Quality>
        </DestinationContext>
        <ContentContext>
          <Content>
```

```

        <Document>
            <Title>Document in eHealthBox</Title>
            <EncryptableBinaryContent/>
            <DownloadFileName>test.txt</DownloadFileName>
            <MimeType>text/plain</MimeType>
        </Document>
        <FreeInformations>
            <EncryptableFreeText/>
        </FreeInformations>
    </Content>
    <ContentSpecification>
        <IsImportant>>false</IsImportant>
        <IsEncrypted>>false</IsEncrypted>
    </ContentSpecification>
    <CustomMeta>
        <Key>CategoryID</Key>
        <Value>2</Value>
    </CustomMeta>
    <CustomMeta>
        <Key>DocumentType</Key>
        <Value>Scan</Value>
    </CustomMeta>
</ContentContext>
</Message>
<MessageInfo>
    <PublicationDate>2011-06-28+02:00</PublicationDate>
    <ExpirationDate>2011-12-31+01:00</ExpirationDate>
    <Size>12</Size>
</MessageInfo>
</ns4:GetFullMessageResponse>
</S:Body>
</S:Envelope>

```

5.3.8 MoveMessage Method

The *MoveMessage* method enables the user to move a message from a *Source* (“INBOX”, “SENTBOX”, “BININBOX”, “BINSENTBOX”) to a *Destination* (“INBOX”, “SENTBOX”, “BININBOX”, “BINSENTBOX”). Only some combinations are allowed as explained below. You need to indicate if a message was received or sent by the concerned eHealthBox. You can do this by looking where the message is situated or compare the currently connected user and the *Sender* and/ or *Destination* element.

Allowed combinations:

Source	Destination
INBOX	BININBOX
SENT BOX	BINSENTBOX
BININBOX	INBOX



BINSENTBOX	SENTBOX
------------	---------

Limitation:

Max 100 messages/requests

5.3.8.1 MoveMessage Request

In Source, specify where the message is currently situated and in Destination, where the message must be moved to. In MessageId specify as many elements as there are messages to be moved. This method can only move 100 messages at a time; consequently, you must use it multiple times if necessary.

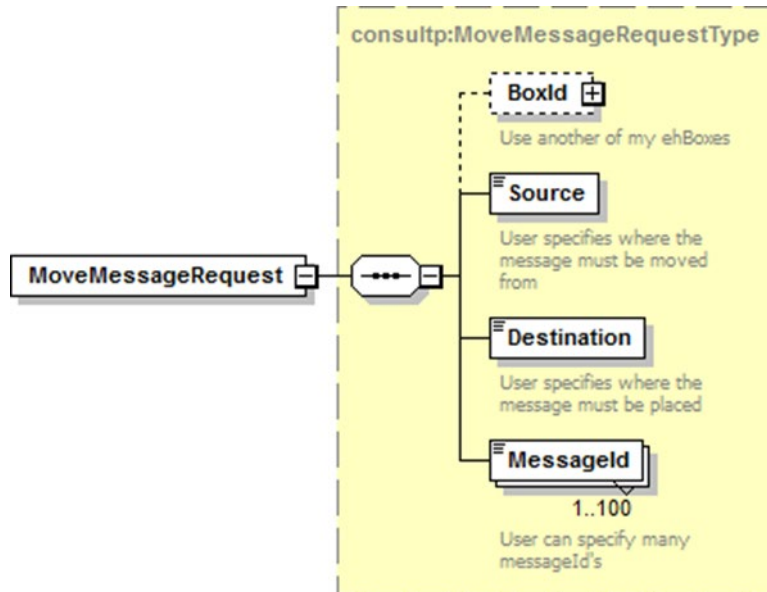

Field name	Description
BoxId	If the client wants to use another of his eHealthBoxes, he can specify it here (see section 5.3.15.3). This avoids the client having to re-authenticate himself each time.
Source	You can define the folder specific to your request via the <i>Source</i> parameter. The possible values are: <ul style="list-style-type: none"> • “INBOX” for the inbox folder. • “SENTBOX” for the sent box folder. • “BININBOX” for messages moved from the inbox folder. • “BINSENTBOX” for messages moved from the sent box folder.
Destination	You can define the folder specific to your request via the <i>Destination</i> parameter. The possible values are: <ul style="list-style-type: none"> • “INBOX” for the inbox folder. • “SENTBOX” for the sent box folder. • “BININBOX” for messages moved from the inbox folder. • “BINSENTBOX” for messages moved from the sent box folder.

MessageId	The <i>MessageId</i> 's corresponding to the message(s) to move.
-----------	--

5.3.8.2 MoveMessage Response

The response contains a success status code or a Business Error as defined in Chapter 8. The Business Error enables you to identify which messages were not successfully moved, even though all other have been moved successfully.

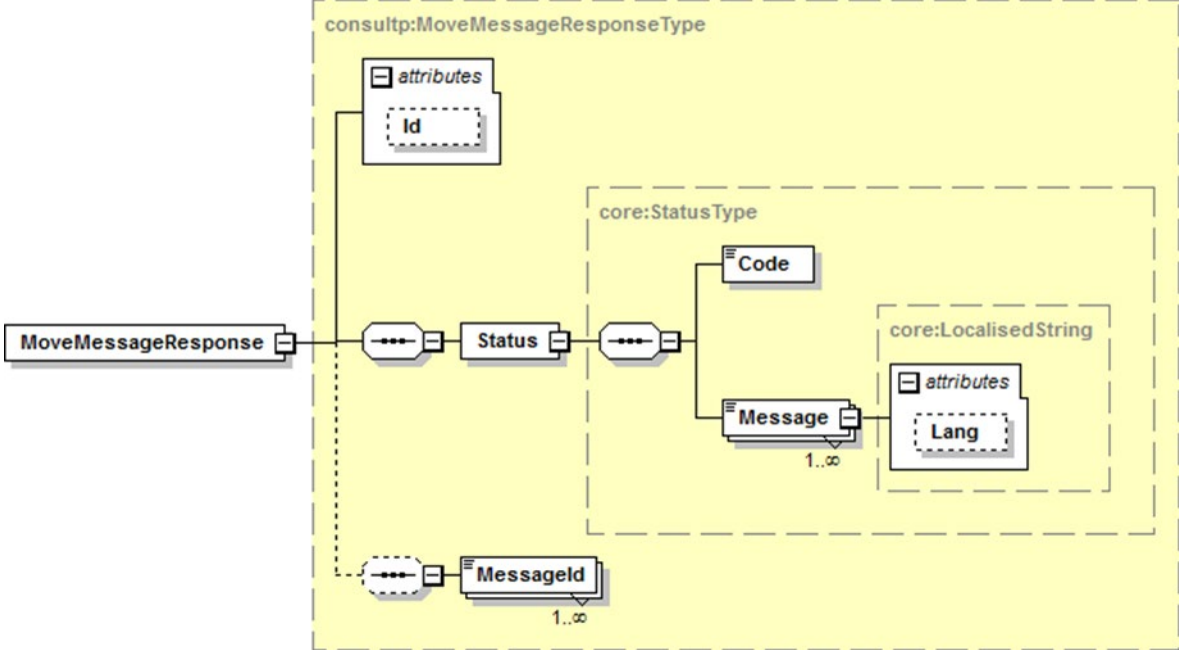

Field name	Description
Id	The ticket number (<i>Id</i>) attributed to the exchange request/response by the eHealth platform is used to identify the session.
Status	<p>The <i>Status</i> block contains a code and a message. If no error has occurred during the transaction, the <i>Code</i> will be '100' and the <i>Message</i> 'SUCCESS'. Otherwise:</p> <p>In case of a business error:</p> <ul style="list-style-type: none"> • The <i>Code</i> is an error code that unequivocally identifies the problem (see Chapter 7 for the possible values). • The <i>Message</i> will be a description of the error. Each <i>Message</i> has a <i>Lang</i> (language) characteristic : <ul style="list-style-type: none"> - "FR": French - "NL": Dutch - "EN": English - "DE": German - "NA": Not applicable <p>In case of technical errors, you will receive a Soap Fault message (see Chapter 8).</p>
MessageId	List of <i>MessageId</i> , which could not be moved. The other messages however were successfully moved.

5.3.8.3 Example

The following example does not contain the SAML assertion.

Request:

```
<soapenv:Envelope
xmlns:soapenv="http://schemas.xmlsoap.org/soap/envelope/"
xmlns:urn="urn:be:fgov:ehhealth:ehbox:consultation:protocol:v3">
  <soapenv:Header/>
  <soapenv:Body>
    <urn:MoveMessageRequest>
      <Source>INBOX</Source>
      <Destination>BININBOX</Destination>
      <MessageId>9Y0002LKM3006</MessageId>
      <MessageId>9Y0002LKM3007</MessageId>
    </urn:MoveMessageRequest>
  </soapenv:Body>
</soapenv:Envelope>
```

Response:

```
<S:Envelope xmlns:S="http://schemas.xmlsoap.org/soap/envelope/">
  <S:Body>
    <ns4:MoveMessageResponse
xmlns:ns2="urn:be:fgov:ehhealth:errors:service:v1"
xmlns:ns4="urn:be:fgov:ehhealth:ehbox:consultation:protocol:v3">
      <Status>
        <Code>813</Code>
        <Message Lang="EN">Not all messages were moved
successfully.
Please verify for each message that the Source and the
MessageID are correct.
Also pay attention that a message in the recycle bin which was moved
from the Inbox cannot be restored back to the Sentbox and vice
versa.</Message>
      </Status>
      <MessageId>9Y0002LKM3006</MessageId>
    </ns4:MoveMessageResponse>
  </S:Body>
</S:Envelope>
```

5.3.9 DeleteMessage Method

The DeleteMessage method enables the user to delete physically and definitely one or more messages from the inbox, sent box or bin. This can be used to clean up the eHealthBox when reaching the size limit. Be cautious when using this method. Best is to show the user a warning message before the deletion of the messages.

Limitation:

Max 100 messages/requests



5.3.9.1 DeleteMessage Request

In MessageId you specify where to delete the messages from: the bin or directly from the inbox or sent box. This method can only delete 100 messages at a time; therefore you must use it multiple times if necessary;

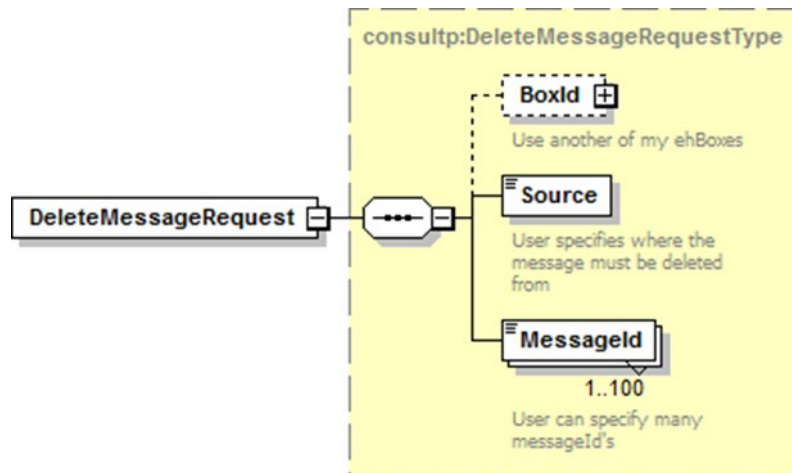

Field name	Description
BoxId	If the client wants to use another of his eHealthBoxes, he can specify it here (see section 5.3.15.3). This avoids him having to re-authenticate each time.
Source	You can define the folder specific to your request via the <i>Source</i> parameter. The possible values are: <ul style="list-style-type: none"> • “INBOX” for the inbox folder. • “SENTBOX” for the sent box folder. • “BININBOX” for messages moved from the inbox folder. • “BINSENTBOX” for messages moved from the sent box folder.
MessageId	The <i>MessageId</i> 's corresponding to the message(s) to delete.

5.3.9.2 DeleteMessage Response

The response contains a success status code or a business error as defined in Chapter 8. The business error enables you to identify which messages have not been deleted successfully, even though all other have been deleted successfully.

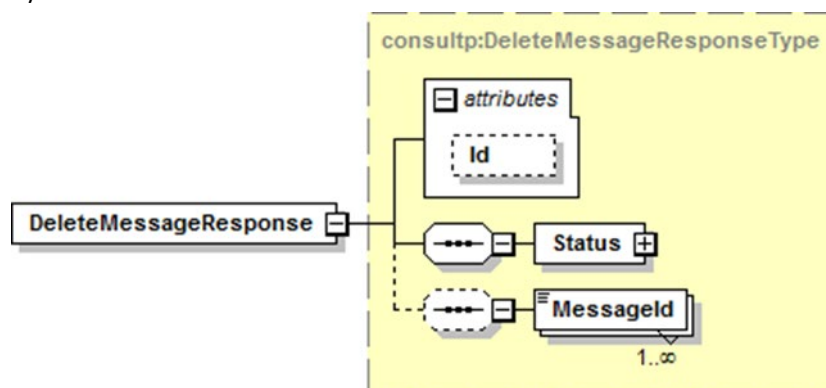

Field name	Description
Id	The ticket number (<i>Id</i>) assigned to the exchange request/response by the eHealth platform is used to identify the eHealth session.
Status	<p>The <i>Status</i> block contains a code and a message. If no error has occurred during the transaction, the <i>Code</i> will be '100' and the <i>Message</i> 'SUCCESS'. Otherwise:</p> <p>In case of a business error:</p> <ul style="list-style-type: none"> • The <i>Code</i> is an error code that unequivocally identifies the problem (see Chapter 7 for the possible values). • The <i>Message</i> will be a description of the error. Each Message has a <i>Lang</i> (language) characteristic : <ul style="list-style-type: none"> - "FR": French - "NL": Dutch - "EN": English - "DE": German - "NA": Not applicable <p>In case of technical errors, you will receive a Soap Fault message (see Chapter 8).</p>
MessageId	List of MessageId which could not be deleted. All other messages were successfully deleted.

5.3.9.3 Example

The following example does not contain the SAML assertion.

Request:

```
<S:Envelope xmlns:S="http://schemas.xmlsoap.org/soap/envelope/">
  <S:Body>
    <ns4:DeleteMessageResponse
xmlns:ns2="urn:be:fgov:ehealth:errors:service:v1"
xmlns:ns4="urn:be:fgov:ehealth:ehbox:consultation:protocol:v3">
      <Status>
        <Code>815</Code>
        <Message Lang="EN">One or more messages couldn't
be deleted. All other messages were successfully deleted.
Please verify for each message that the MessageId is correct, and it
is in the Inbox or in the recycle bin.</Message>
      </Status>
      <MessageId>9Y0002LKM3006</MessageId>
    </ns4:DeleteMessageResponse>
  </S:Body>
</S:Envelope>
```

5.3.10 getHistory Method

This method is decommissioned since HC version and deletions of 'NEWS'

The getHistory method was used to get the older message versions of a "news" type message. The method returns a list of MessageId's corresponding to the previous version of a "news item".

A call to GetHistoryRequest will respond an HTTP 500 (with SOA-02001 error)



5.3.11 GetMessageAcknowledgmentsStatus Method

The *GetMessageAcknowledgmentsStatus* method is used to find out which message the user has sent, which recipients have received, viewed or read the message and at what time.

5.3.11.1 GetMessageAcknowledgmentsStatus Usage

It is strongly advised not to regularly use this method. Moreover, it is forbidden to base your ACK management business on this method !

You should prefer requesting the receipt of acknowledgments via booleans to true when publishing, and manage Ack received. (See Publication Cookbook).

Note that a *GetMessageAcknowledgmentsStatus* request on a message already deleted will **cause an error (809)**. This means that when you make a status request on a message the recipient has already deleted, this will generate an error, hence the limited use of this method.

5.3.11.2 GetMessageAcknowledgmentsStatus Request

This method can only return 100 acknowledgements at a time; thus, you should call upon it multiple times if necessary.

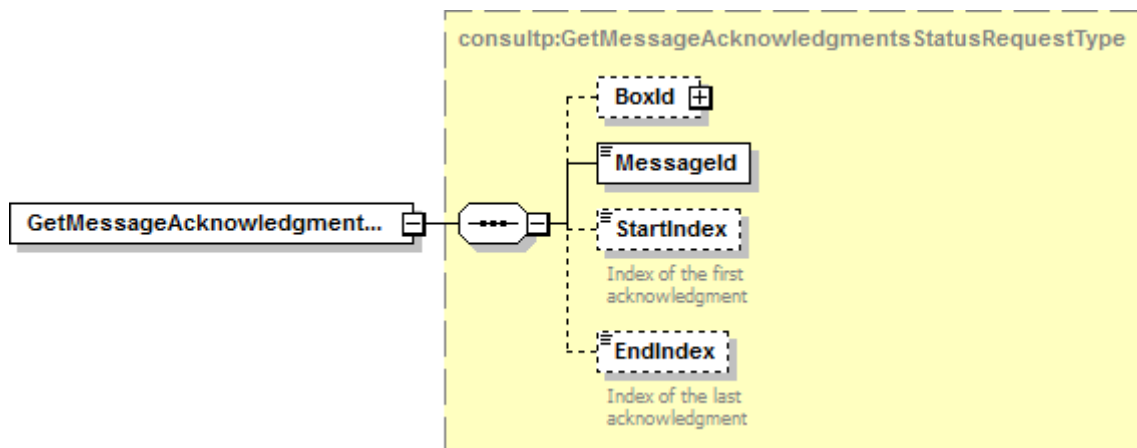

Field name	Description
BoxId	When the client wants to use another of his eHealthBoxes, he can specify it here (see section 5.3.15.3). This avoids him having to re-authenticate each time.
MessageId	The <i>MessageId's</i> of the message to consult. The <i>MessageId</i> is a unique message identification generated by the system and returned during the publication and when calling upon the <i>getMessagesList</i> . String of 13 digits.
StartIndex	Index of the first acknowledgment (minimum 1)
EndIndex	Index of the last acknowledgment (minimum 1). A maximum of 100 acknowledgments can be returned at once. $EndIndex < StartIndex + 100$

5.3.11.3 GetMessageAcknowledgmentsStatus Response

The response gives you information about your sent message: who received and read your message at what time.

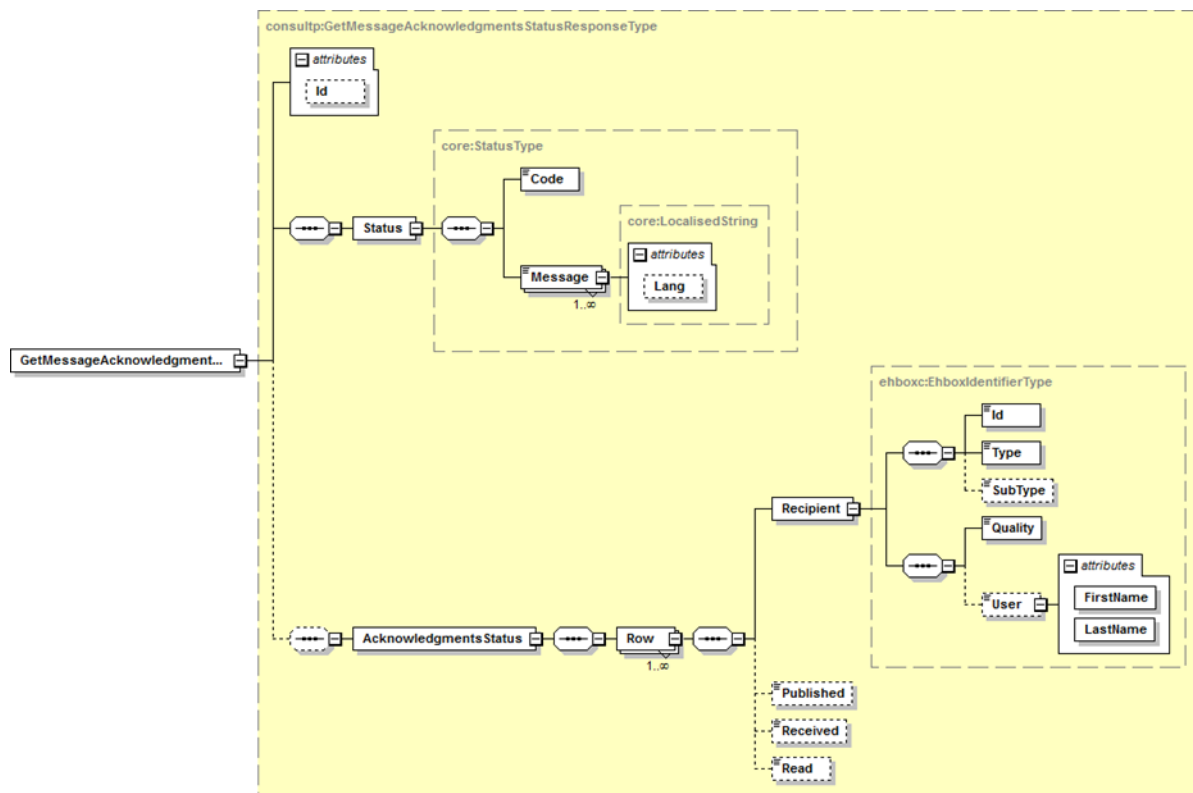

Field name	Description
Id	The ticket number (<i>Id</i>) assigned to the exchange request/response by the eHealth platform, used to identify the eHealth session.
Status	<p>The <i>Status</i> block contains a code and a message. If no error has occurred during the transaction, the <i>Code</i> will be '100' and the <i>Message</i> 'SUCCESS'. Otherwise:</p> <p>In case of a business error:</p> <ul style="list-style-type: none"> • The <i>Code</i> is an error code that unequivocally identifies the problem (see Chapter 7 for the possible values). • The <i>Message</i> will be a description of the error. Each <i>Message</i> has a <i>Lang</i> (language) characteristic : <ul style="list-style-type: none"> - "FR": French - "NL": Dutch - "EN": English - "DE": German - "NA": Not applicable <p>In case of technical errors, you will receive a Soap Fault message (see Chapter 8).</p>
AcknowledgmentsStatus	Contains a <i>Row</i> for each different <i>Recipient</i> of the message. Each <i>Row</i> contains the identification of the <i>Recipient</i> (Type <i>EhboxIdentifier</i> , see section 5.3.15.16), the time the message was published, the time the message was received (=viewed) by that <i>Recipient</i> , as well as the time it had been read.

5.3.11.4 Example

The following example does **not** contain the SAML assertion.

Request:

```
<soapenv:Envelope
xmlns:soapenv="http://schemas.xmlsoap.org/soap/envelope/"
xmlns:urn="urn:be:fgov:ehhealth:ehbox:consultation:protocol:v3">
  <soapenv:Header/>
  <soapenv:Body>
    <urn:GetMessageAcknowledgmentsStatusReq
      uest>
      <MessageId>9Y0002LKH020J</MessageId>
      <StartIndex>1</StartIndex>
      <EndIndex>100</EndIndex>
    </urn:GetMessageAcknowledgmentsStatusRequest>
  </soapenv:Body>
</soapenv:Envelope>
```

Response:

```
<S:Envelope xmlns:S="http://schemas.xmlsoap.org/soap/envelope/">
  <S:Body>
    <ns4:GetMessageAcknowledgmentsStatusResponse
xmlns:ns2="urn:be:fgov:ehhealth:errors:service:v1"
xmlns:ns4="urn:be:fgov:ehhealth:ehbox:consultation:protocol:v3">
      <Status>
        <Code>100</Code>
        <Message Lang="EN">SUCCESS</Message>
      </Status>
      <AcknowledgmentsStatus>
        <Row>
          <Recipient>
            <Id>999999999965</Id>
            <Type>INSS</Type>
            <Quality>DOCTOR</Quality>
            <User
LastName="Francois"
FirstName="Pignon">999999999965</User>
          </Recipient>
          <Published>2011-12-17T09:30:47Z</Published>
          <Received>2011-12-17T10:31:17Z </Received>
          <Read>2011-12-17T09:30:47Z </Read>
        </Row>
      </AcknowledgmentsStatus>
    </ns4:GetMessageAcknowledgmentsStatusResponse>
  </S:Body>
</S:Envelope>
```

5.3.12 InsertOoO Method

The *InsertOoO* method is used to insert an OoO for the considered eHealthBox. In order to insert an OoO for another eHealthBox, BoxId can be used. There are a number of rules and limitations to respect as described in section 5.3.2.2. If these rules are not respected, a business error is returned as detailed in section 8.2.

5.3.12.1 InsertOoO Request

Only one OoO can be inserted by request, but multiple substitutes may be specified.

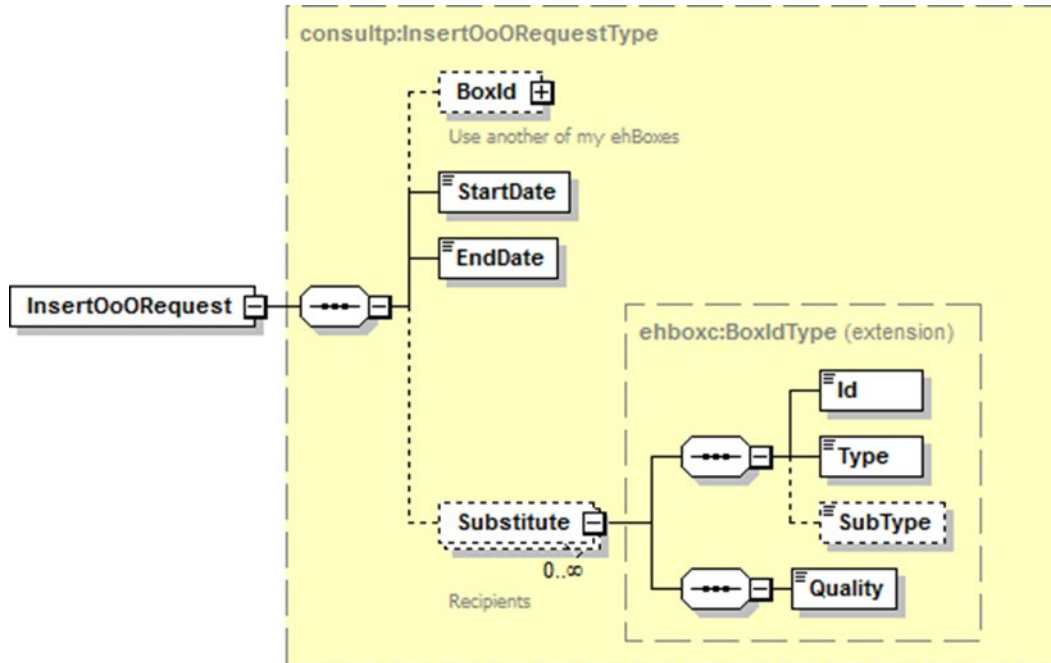

Field name	Description
BoxId	When the client wants to use another of his eHealthBoxes, he can specify it here (see section 5.3.15.3). This avoids him having to re-authenticate himself each time.
StartDate	The <i>StartDate</i> of the OoO. This date is inclusive. Ex. 2013-07-03+02:00
EndDate	The <i>EndDate</i> of the OoO. This date is inclusive. Ex. 2013-07-17+02:00
Substitue	Optional. You may want to specify someone, which is replacing you during your absence. The structure is as usual, detailed in 5.3.15.3

5.3.12.2 InsertOoO Response

The response is “Success” without further details if everything went well. Otherwise the wrong or absent substitutes will be returned in the response as detailed below.

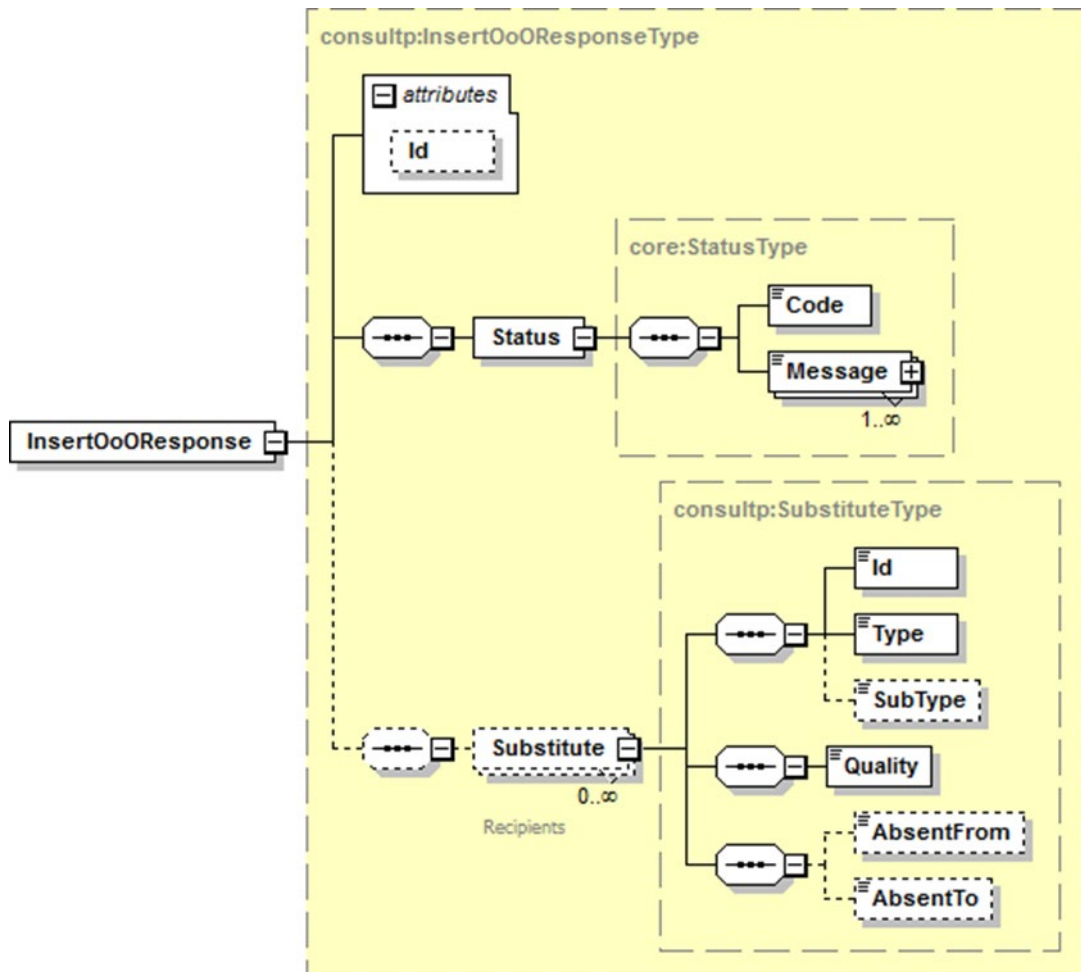

Field name	Description
Id	The Id element contains the OoOId attributed to this OoO by the system, which can later be used in DeleteOoO for example.

Status	<p>The <i>Status</i> block contains a code and a message. When no error has occurred during the transaction, the <i>Code</i> will be '100' and the <i>Message</i> 'SUCCESS'. Otherwise:</p> <p>In case of a business error:</p> <ul style="list-style-type: none"> • The <i>Code</i> is an error code that unequivocally identifies the problem (see Chapter 7 for the possible values). • The <i>Message</i> will be a description of the error. Each <i>Message</i> has a <i>Lang</i> (language) characteristic : <ul style="list-style-type: none"> - "FR": French - "NL": Dutch - "EN": English - "DE": German - "NA": Not applicable <p>In case of technical errors, you will receive a Soap Fault message (see Chapter 8).</p>
Substitute	<p>Contains a <i>Row</i> for each different <i>Substitute</i> which is incorrect, unknown, or absent (absence period of this substitute is then specified).</p>

5.3.12.3 Example

The following example does **not** contain the SAML assertion.

Request:

```

<soapenv:Envelope
xmlns:soapenv="http://schemas.xmlsoap.org/soap/envelope/"
xmlns:urn="urn:be:fgov:ehhealth:ehbox:consultation:protocol:v3">
  <soapenv:Header/>
  <soapenv:Body>
    <urn:InsertOoORequest>
      <BoxId>
        <Id>710000000</Id>
        <Type>NIHII</Type>
        <Quality>DOCTOR</Quality>
      </BoxId>
      <StartDate>2013-07-03+02:00</StartDate>
      <EndDate>2013-07-17+02:00</EndDate>
      <Substitute>
        <Id>11111111111</Id>
        <Type>INSS</Type>
        <Quality>DOCTOR</Quality>
      </Substitute>
    </urn:InsertOoORequest>
  </soapenv:Body>
</soapenv:Envelope>

```

Response:

```
<S:Envelope xmlns:S="http://schemas.xmlsoap.org/soap/envelope/">
  <S:Body>
    <ns4: InsertOoOResponse
xmlns:ns2="urn:be:fgov:ehhealth:errors:service:v1"
xmlns:ns4="urn:be:fgov:ehhealth:ehbox:consultation:protocol:v3">
      <Status>
        <Code>824</Code>
        <Message Lang="EN">One or more substitutes cannot be
chosen because they are absent.</Message>
      </Status>
      <Substitute>
        <Id>1111111111</Id>
        <Type>INSS</Type>
        <Quality>DOCTOR</Quality>
      </Substitute>
    </ns4: InsertOoOResponse>
  </S:Body>
</S:Envelope>
```

5.3.13 DeleteOoO Method

The *DeleteOoO* method is used to delete an OoO for the considered eHealthBox. In order to delete an OoO for another eHealthBox, BoxId can be used. The OoO Id must be specified. It can be retrieved from InsertOoO, in the Id element or from GetOoOList.

5.3.13.1 DeleteOoO Request

Only one OoO can be inserted by request, but multiple substitutes may be specified.

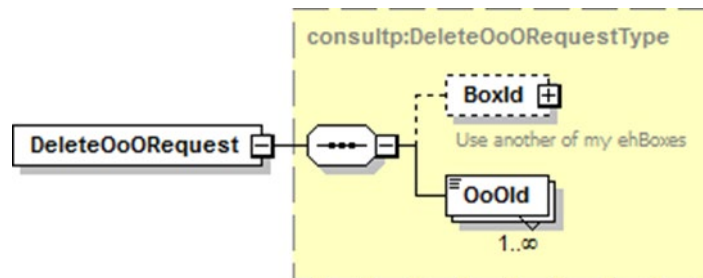

Field name	Description
BoxId	If the client wants to use another of his eHealthBoxes, he can specify it here (see section 5.3.15.3). This avoids him having to re-authenticate each time.
OoOld	The OoOld from the OoOs that the user wants to delete. The OoOld's can be retrieved from InsertOoO, in the Id element or from GetOoOList.

5.3.13.2 DeleteOoO Response

The response is "Success" without further details if everything went well. Otherwise, the OoOld which could not be found, will be returned in the response as detailed below. All other OoO found, were deleted.



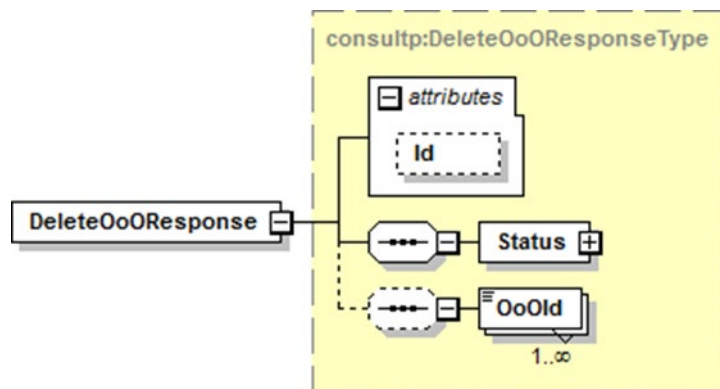

Field name	Description
Id	The ticket number (<i>Id</i>) attributed to the exchange request/response by the eHealth platform, used to identify the eHealth session.
Status	The <i>Status</i> block contains a code and a message. When no error has occurred during the transaction, the <i>Code</i> will be '100' and the <i>Message</i> 'SUCCESS'. Otherwise: In case of a business error: <ul style="list-style-type: none"> The <i>Code</i> is an error code that unequivocally identifies the problem (see Chapter 7 for the possible values).
	<ul style="list-style-type: none"> The <i>Message</i> will be a description of the error. Each <i>Message</i> has a <i>Lang</i> (language) characteristic : <ul style="list-style-type: none"> "FR": French "NL": Dutch "EN": English "DE": German "NA": Not applicable In case of technical errors, you will receive a Soap Fault message (see Chapter 8).
OoOld	Contains the OoOld's which could not be found and were not deleted. All others were deleted.

5.3.13.3 Example

The following example does not contain the SAML assertion.

Request:

```

<soapenv:Envelope
  xmlns:soapenv="http://schemas.xmlsoap.org/soap/envelope/"
  xmlns:urn="urn:be:fgov:ehealth:ehbox:consultation:protocol:v3">
  <soapenv:Header/>
  <soapenv:Body>
    <urn>DeleteOoRequest>
      <BoxId>
        <Id>99999999964</Id>
        <Type>INSS</Type>
        <Quality>DOCTOR</Quality>
      </BoxId>
    </urn>
  </soapenv:Body>
</soapenv:Envelope>
  
```



```

        </BoxId>
        <OoOId>1005</OoOId>
    </urn:DeleteOoORequest>
</soapenv:Body>
</soapenv:Envelope>

```

Response:

```

<S:Envelope xmlns:S="http://schemas.xmlsoap.org/soap/envelope/">
  <S:Body>
    <ns4: DeleteOoOResponse
xmlns:ns2="urn:be:fgov:ehealth:errors:service:v1"
xmlns:ns4="urn:be:fgov:ehealth:ehbox:consultation:protocol:v3">
      <Status>
        <Code>840</Code>
        <Message Lang="EN">One or more OoOId are invalid.</Message>
      </Status>
      <OoOId>1005</OoOId>
    </ns4:DeleteOoOResponse>
  </S:Body>
</S:Envelope>

```

5.3.14 GetOoOList Method

The *GetOoOList* method is used to list all inserted OoO for the considered eHealthBox. The list contains all OoO: past, active and future OoO. The OoOId returned, can further be used to delete an OoO.

5.3.14.1 GetOoOList Request

Only one OoO can be inserted by request, but multiple substitutes may be specified.

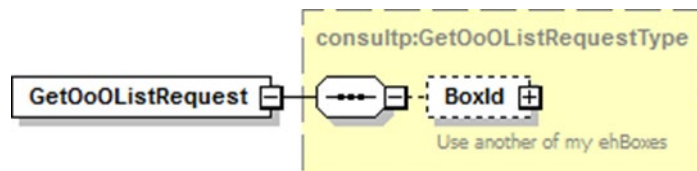

Field name	Description
BoxId	If the client wants to use another of his eHealthBoxes, he can specify it here (see section 5.3.15.3). This avoids him having to re-authenticate each time.

5.3.14.2 GetOoOList Response

The response contains a success status code and as many OoO elements as there are OoO in the considered eHealthBox. Each element contains all OoO data when it was inserted.

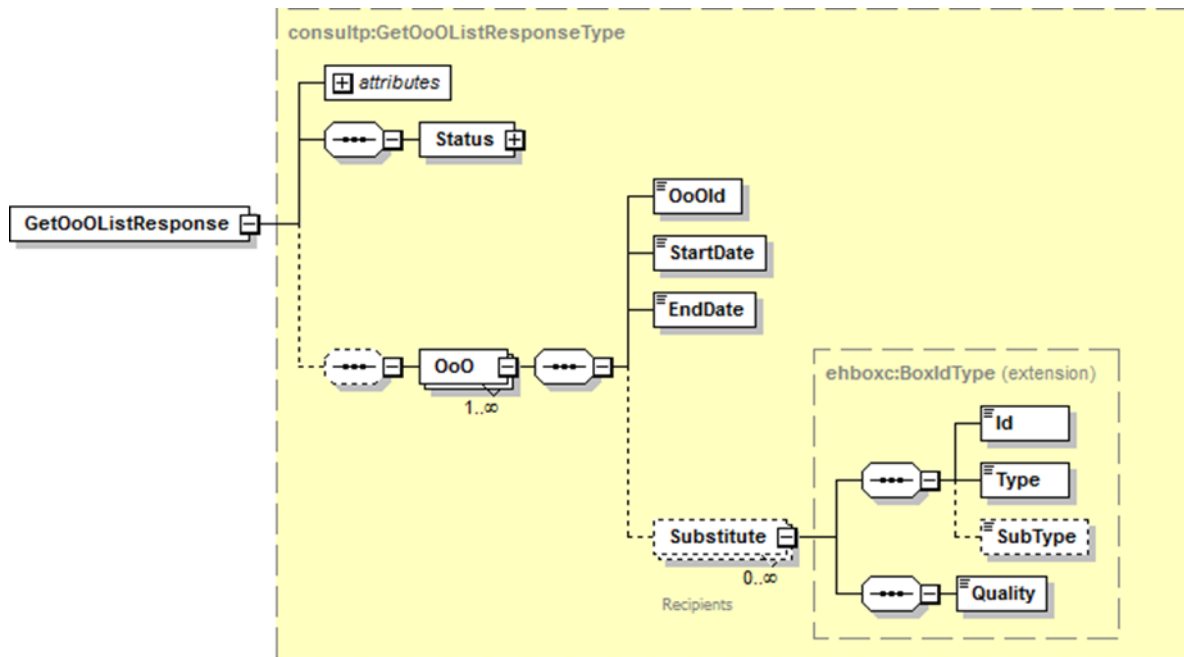

Field name	Description
OoOld	The OoOld assigned by the system to the OoO.
StartDate	The <i>StartDate</i> of the OoO. This date is inclusive. E.g. 2013-07-03+02:00
EndDate	The <i>EndDate</i> of the OoO. This date is inclusive. E.g. 2013-07-17+02:00
Substitue	Optional. The person who is replacing the absentee. The structure is as usual (details in 5.3.15.3)

5.3.14.3 Example

The following example does **not** contain the SAML assertion.

Request:

```
<soapenv:Envelope
  xmlns:soapenv="http://schemas.xmlsoap.org/soap/envelope/"
  xmlns:urn="urn:be:fgov:ehhealth:ehbox:consultation:protocol:v3">
  <soapenv:Header/>
  <soapenv:Body>
    <urn:GetOoOListRequest/>
  </soapenv:Body>
</soapenv:Envelope>
```

Response:

```
<S:Envelope xmlns:S="http://schemas.xmlsoap.org/soap/envelope/">
  <S:Body>
    <ns4: GetOoOListResponse
      xmlns:ns2="urn:be:fgov:ehhealth:errors:service:v1"
      xmlns:ns4="urn:be:fgov:ehhealth:ehbox:consultation:protocol:v3">
```

```

<Status>
  <Code>100</Code>
  <Message Lang="EN">SUCCESS</Message>
</Status>
<OoO>
  <OoOId>1000</OoOId>
  <StartDate>2013-07-03+02:00</StartDate>
  <EndDate>2013-07-17+02:00</EndDate>
  <Substitute>
    <Id>11111111111</Id>
    <Type>INSS</Type>
    <Quality>DOCTOR</Quality>
  </Substitute>
</OoO>
</ns4:GetOoOListResponse>
</S:Body>
</S:Envelope>

```

5.3.15 Used types

5.3.15.1 Acknowledgment

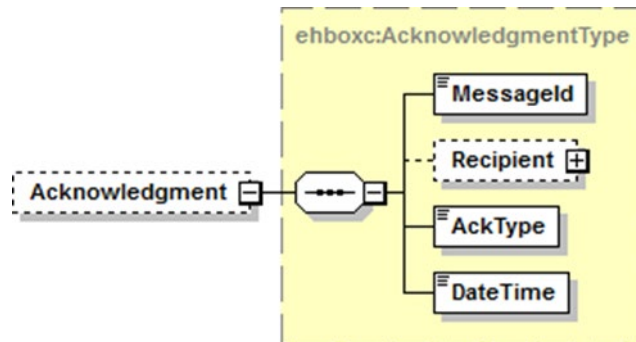

Field name	Descriptions
MessageId	The MessageId of the original message.
Recipient	The recipient receiving or reading the original message. This element is only present for an acknowledgment of type 'RECEIVED' or 'READ'.
AckType	3 acknowledgment types exist: 'PUBLISHED', 'RECEIVED' and 'READ': <ul style="list-style-type: none"> An ack. 'published' => when the system is treating the original message An ack. 'Received' => when the recipient has seen the original message (request getMessageList) An ack. 'Read' => when the recipient has opened the original message (request getFullMessage)
DateTime	Date & Time when the acknowledgment was issued. E.g. <DateTime>2001-12-17T09:30:47Z</DateTime>

5.3.15.2 Annex

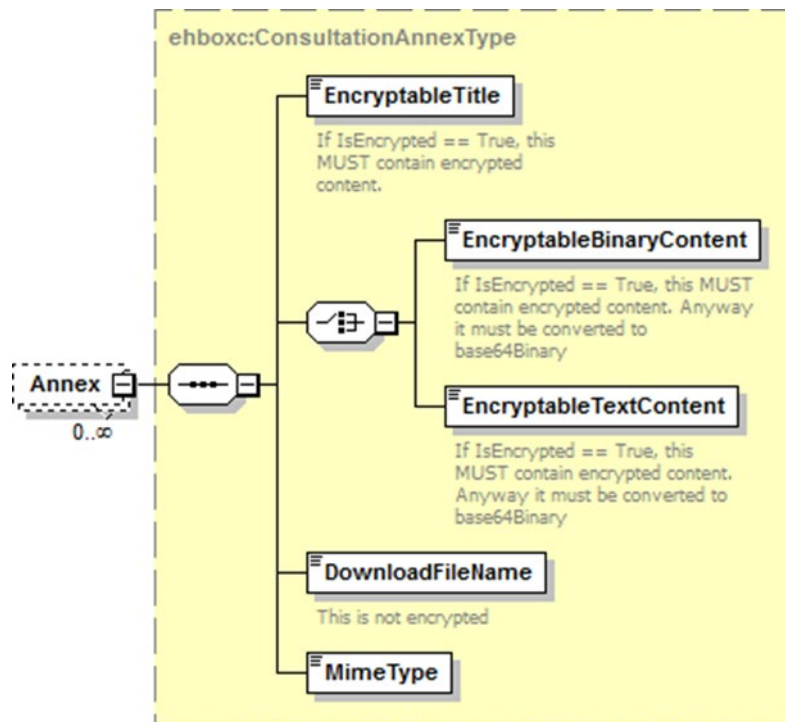

Field name	Descriptions
EncryptableTitle	An <i>Annex</i> has an <i>EncryptableTitle</i> , a human readable description of its content (minimum 1, maximum 400 characters in binary form). If <i>IsEncrypted</i> is true (see Section 5.3.15.7), the title must be encrypted (see section 5.1.2).
EncryptableBinaryContent	Contains a SOAP reference to the attachment E.g. <EncryptableBinaryContent>cid:4906633928</EncryptableBinaryContent>. Type is xsd:anyURI. If <i>IsEncrypted</i> is true (see Section 5.3.15.7), the attachment must be encrypted (see section 5.1.2).
EncryptableTextContent	Text content, in binary form. If <i>IsEncrypted</i> is true (see Section 5.3.15.7), the text content must be encrypted (see section 5.1.2).
DownloadFileName	E.g. “principal.pdf” (string minimum 1, maximum 255).
MimeType	Represents the mime type of the content. E.g. “application/pdf”, “text/plain”, “application/octet-stream” (string minimum 1, maximum 255).

5.3.15.3 BoxId

A *BoxId* contains all the information on the eHealthBox the client wants to use for the request.

BoxId cannot be used when authenticated as an organization.

You will find all mandatory information about the allowed combinations *Id-Type- Quality* (See eHealthBox – Supported qualities v1.2).

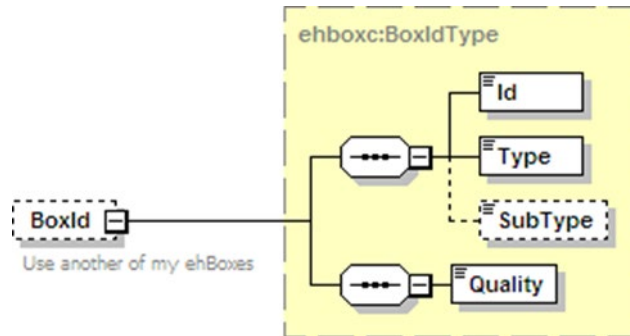

Field name	Descriptions
ID	Your eHealthBox’s identification number. This is a digital number representing an INSS, NIHII, FAMPH, or CBE. String.
Type	Your eHealthBox’s ID type (“INSS”, “NIHII”, “FAMPH” or “CBE”). String.
Subtype (obsolete)	If the recipient is an organization, the <i>Subtype</i> allows (if necessary) further specification (such as "HOSPITAL" <i>SubType</i> for a Hospital <i>Quality</i> , or "GROUP" <i>SubType</i> for a Group <i>Quality</i>). String.
Quality	Your eHealthBox’s <i>Quality</i> . String (See eHBox_Quality)

5.3.15.4 Content

A Content contains the message content (a document or a news item) and optionally zero-or-more free information, a Patient INSS and zero-or-more annexes.

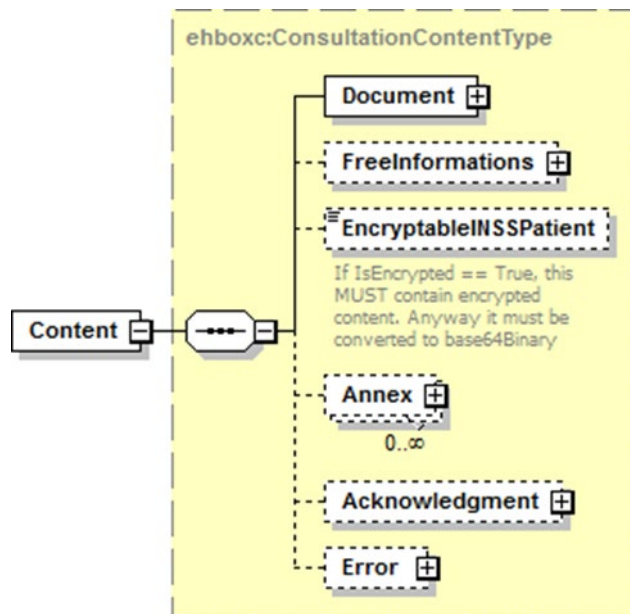

Field name	Descriptions
Document	A news item is now a special case of a document. See section 5.3.15.10
FreeInformations	See section 5.3.15.12

EncryptableINSSPatient	This optional field allows specifying an INSS number of a patient concerned by the message content. If <i>IsEncrypted</i> is true (see Section 5.3.15.7), the INSS number must be encrypted (see section 5.1.2).
Annex	See section 5.3.15.2
Acknowledgment	See section 5.3.15.1
Error	See section 5.3.15.11

5.3.15.5 ContentContext

A *ContentContext* contains the message content and message details, as well as zero or more (50 maximum) free *CustomMetas*. The user for internal usage can freely specify these CustomMetas. You can define a Key and a value for each *CustomMeta* (see 5.3.15.8).

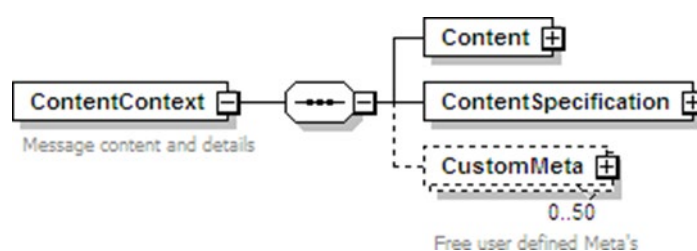

5.3.15.6 ContentInfo

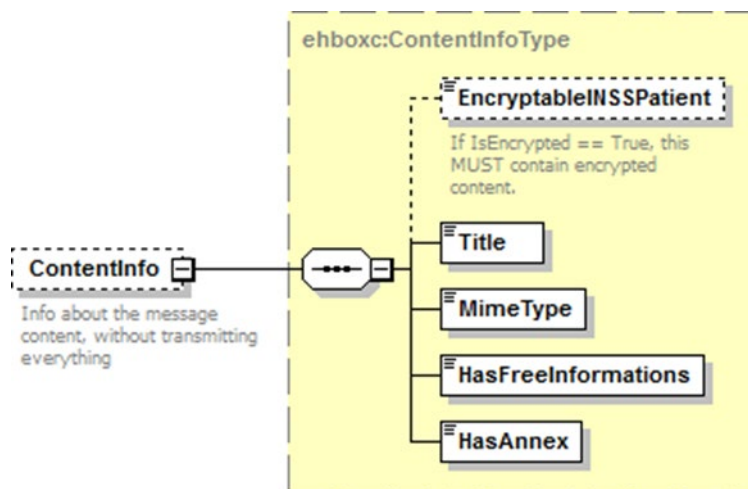

Field name	Descriptions
EncryptableINSSPatient	This optional field allows specifying an INSS number of a patient concerned by the message content. If <i>IsEncrypted</i> is true (see Section 5.3.15.7), the content must be encrypted before being converted to xs:base64Binary (see section 5.1.2).
Title	The <i>Title</i> of the message, a human readable description of its purpose (string minimum 1, maximum 400).
MimeType	Represents the mime type of the content. E.g. "application/pdf", "text/plain", "application/octet-stream" (string minimum 1, maximum 255).

HasFreeInformation	A flag (true or false) indicating whether the message has any <i>Free Information</i> .
HasAnnex	A flag (true or false) indicating whether the message has an <i>Annex</i> .

5.3.15.7 ContentSpecification

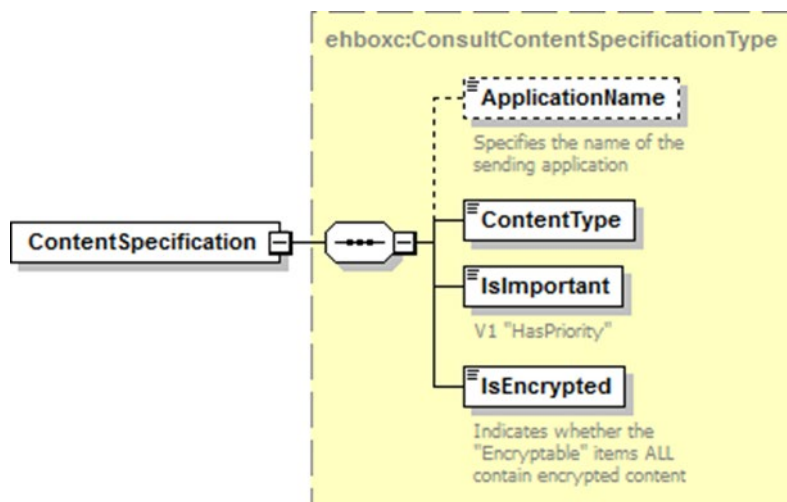

Field name	Descriptions
ApplicationName	The Application sending the message (optional, string minimum 1, maximum 25).
ContentType	The <i>Content Type</i> of the message ("DOCUMENT", "NEWS", "ACKNOWLEDGMENT", "ERROR").
IsImportant	Boolean (true or false) indicating whether the message is to be considered as important.
IsEncrypted	Boolean (true or false) indicating whether the content has been encrypted.

5.3.15.8 CustomMeta

CustomMeta was introduced in order to enable the client to transport any Meta information relative to the message he wants. You can specify a maximum of 50 different pairs (key, value). The fields are limited each to 250 characters. Those *CustomMetas* will be transported from the sender to the recipient. You can e.g. example add a *CustomMeta* for internal usage as "CategoryId, 17", or "MessageContent, Blood analysis".

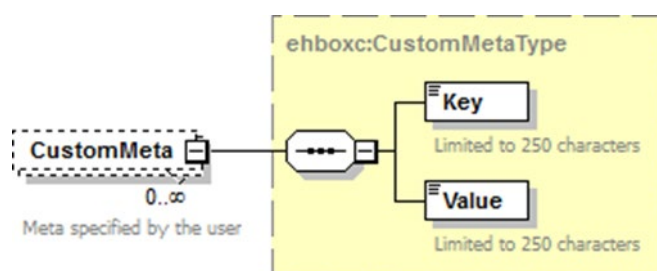

Field name	Description
Key	Alphanumeric string used as a key (string minimum 1, maximum 250)
Value	Alphanumeric string value corresponding to the <i>Key</i> (string minimum 1, maximum 250)

5.3.15.9 DestinationContext

A *DestinationContext* contains all the information on the recipient.

You will find all the essential information about the allowed combinations Id-Type- Quality (See eHealthBox – Supported qualities v1.1).

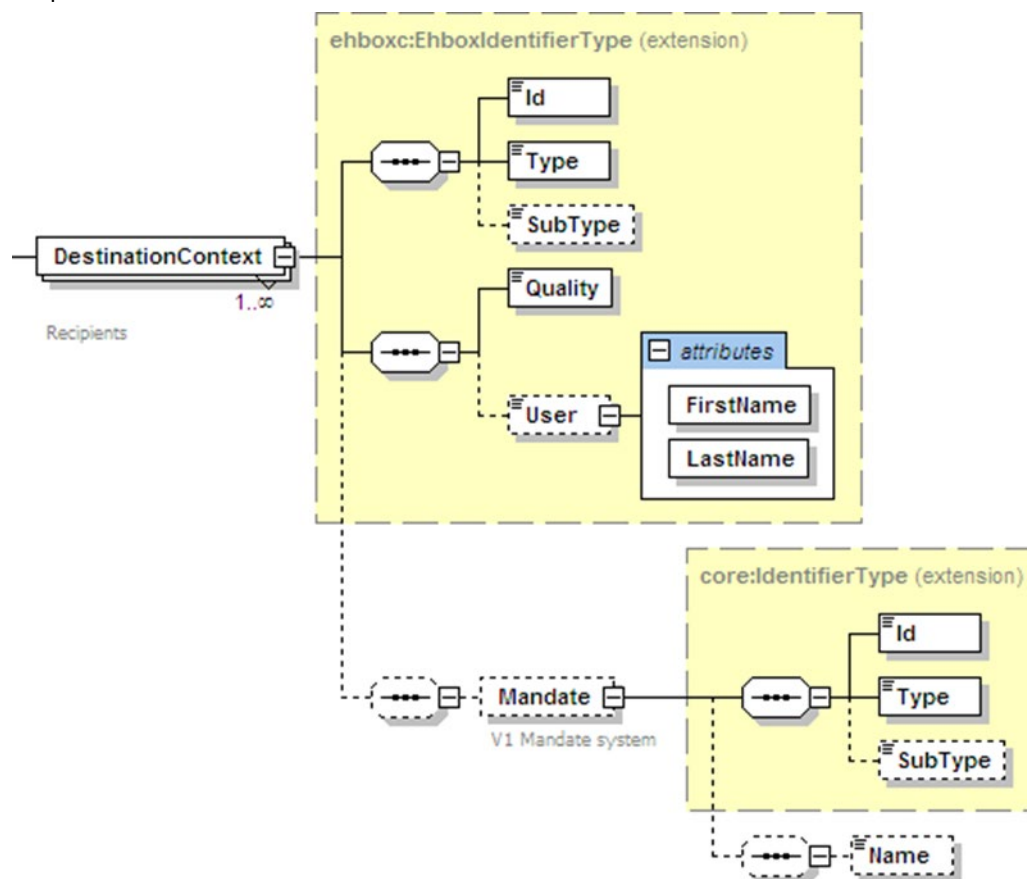

Field name	Description
ID	The recipient's identification number. This is a digital number representing an INSS, NIHII, FAMPH, or CBE. String.
Type	The recipient's ID type ("INSS", "NIHII", "FAMPH" or "CBE"). String.
Subtype (obsolete)	If the recipient is an organization, the <i>Subtype</i> allows (if necessary) further specification (such as "HOSPITAL" <i>SubType</i> for a Hospital <i>Quality</i> , or "GROUP" <i>SubType</i> for a Group <i>Quality</i>). String.
Quality	A <i>Quality</i> defines the recipient's eHealthBox. String (see reference 4 of eHealth platform documents)

User	An optional <i>User</i> (<i>FirstName</i> and <i>LastName</i>) can be added in the destination context. In case of a publication to an organization, this field is used to specify a member of this organization (e.g. a doctor working in a hospital), (string minimum 1, maximum 100). String.
Mandate (obsolete)	Optional authority information will be added if the recipient has been granted an authority. The constituent's identification number (<i>Id</i>) and <i>Type</i> are requested. If the constituent is an organization, the <i>Subtype</i> allows (if necessary) further specification (such as "HOSPITAL" <i>SubType</i> for a <i>Hospital Quality</i> , or "GROUP" <i>SubType</i> for a <i>Group Quality</i>). The recipient's name may be specified.

5.3.15.10 Document

Please note that a message will contain either a news item or a document, not both.

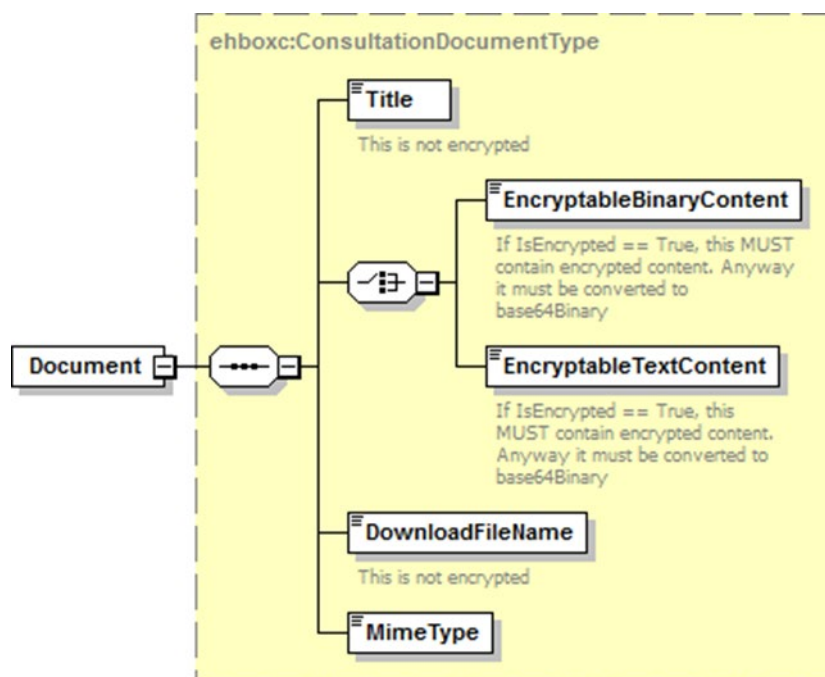

Field name	Description
Title	A Document has a <i>Title</i> , a human readable description of its intent (string minimum 1, maximum 400).
EncryptableBinaryContent	Contains a SOAP reference to the attachment E.g. <code><EncryptableBinaryContent>cid:4906633928</EncryptableBinaryContent></code> . Type is <code>xsd:anyURI</code> .
	If <i>IsEncrypted</i> is true (see Section 5.3.15.7), the attachment must be encrypted (see section 5.1.2).
EncryptableTextContent	Text content, in binary form. If <i>IsEncrypted</i> is true (see Section 5.3.15.7), the text content must be encrypted (see section 5.1.2).
DownloadFileName	E.g. "principal.pdf" (string minimum 1, maximum 255).
MimeType	Represents the mime type of the content. E.g. "application/pdf", "text/plain", "application/octet-stream" (string minimum 1, maximum 255).

5.3.15.11 Error

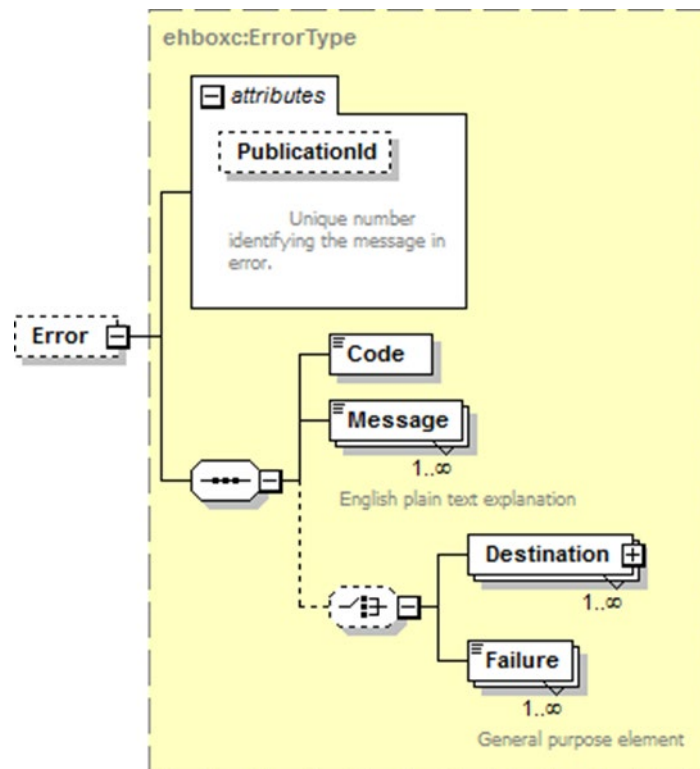

Field name	Description
PublicationId	The PublicationId of the sent message (in error).
Code	The Error Code as defined in table 8.1. The number of possible error codes can evolve.
Message	A human readable English message.
Destination	The recipient causing an error e.g. because he could not be found. Check if the identifier and identifier type is correct.
Failure	All-purpose field containing technical Ids as PublicationId or MessageId. Not currently used, but for future needs.

5.3.15.12 FreeInformations

The sender is free to add more information via the *FreeInformations* field, which will be transparently provided to the recipient(s).

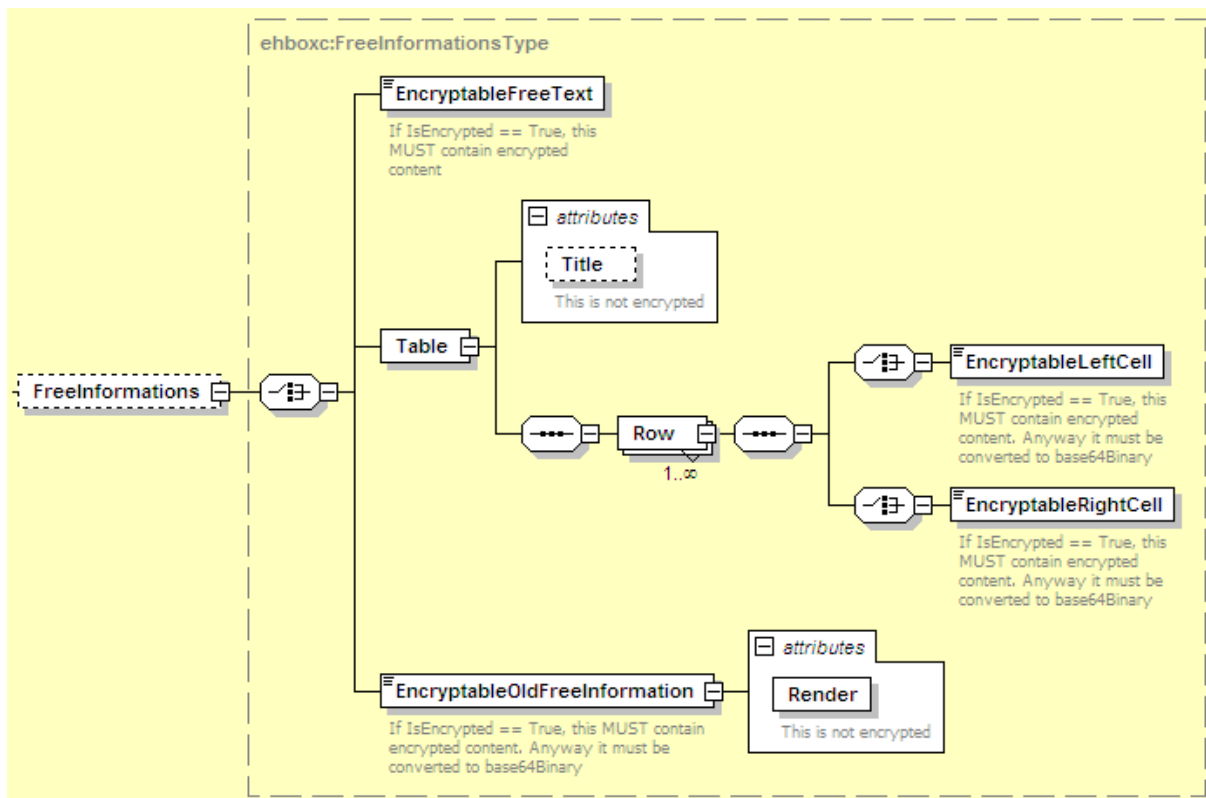

Field name	Description
EncryptableFreeText	Text content, in binary form. If <i>IsEncrypted</i> is true (see section 5.3.15.7), the text must be encrypted (see section 5.1.2).
Table	<i>Title</i> (the title of the table) and 1 or more <i>Row</i> (s) (each <i>Row</i> has a <i>EncryptableLeftCell</i> and a <i>EncryptableRightCell</i> as string). If <i>IsEncrypted</i> is true (see section 5.3.15.7), the content must be encrypted (see section 5.1.2).
EncryptableOldFreeInformation (obsolete)	Text content, in binary form and a <i>Render</i> attribute (as a string). If <i>IsEncrypted</i> is true (see section 5.3.15.7), the content must be encrypted (see section 5.1.2).

5.3.15.13 Message

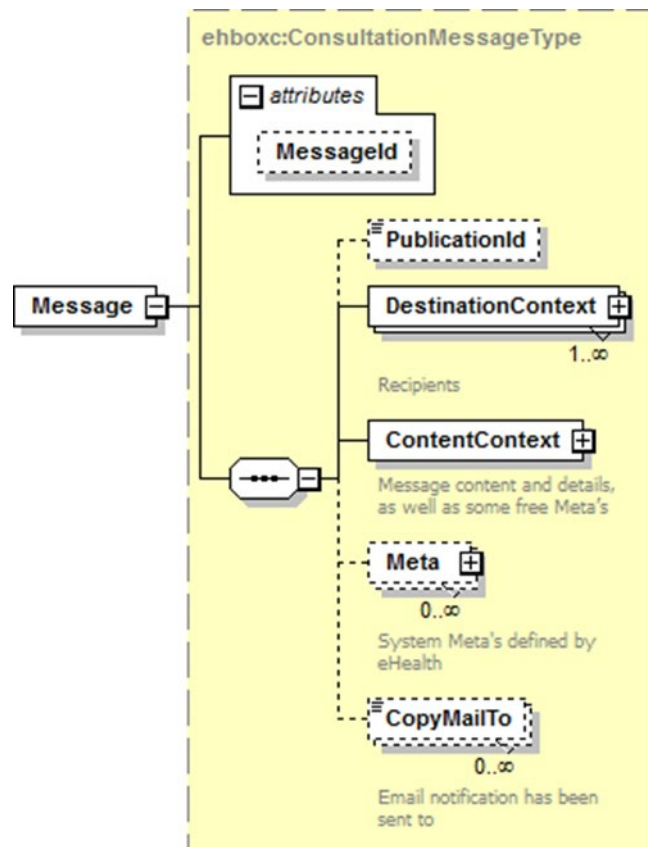

Field name	Description
MessageId	The <i>MessageId</i> is a unique message identification generated by the system and returned during the publication and when calling upon the <code>getMessagesList</code> . String of 13 digits.
PublicationId	The Id that the sender has used to publish the message. String, minimum 1, maximum 13.
DestinationContext	The <i>DestinationContext</i> is a complex type that contains information about the recipients. See details in section 5.3.15.9. A <i>Message</i> can have numerous <i>DestinationContext</i> (numerous recipients).
ContentContext	The <i>ContentContext</i> is a complex type that contains the message content. See details in section 5.3.15.5.
Meta	Currently, no meta information is defined. Additional system meta information can be defined by the eHealth platform and used in convention with the client (for future needs). The type of meta information must be defined in the eHealthBox system before it can be used (see section 5.3.15.15).
CopyMailTo	One or more email address(es) that will receive a notification when the message has been published (optional, string minimum 1, maximum 80). If you would like to notify more than one recipient, you can add each e-mail address in a separate <i>CopyMailTo</i> element. By default, a notification will be sent to the hospital's security manager (registered in the user management of the social security) or in case of a

	publication to an individual person (doctor, citizen...): the person will receive a notification if he has updated his email address on the web application 'eHealthBox Webapp' (in the configuration section of this WebApp)
--	---

5.3.15.14 MessageInfo

A *MessageInfo* contains short details about the message.

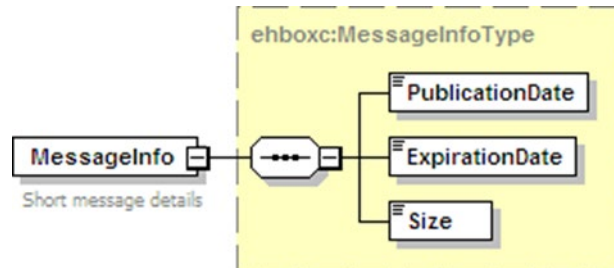

Field name	Description
PublicationDate	The <i>Date</i> on which the message has been published (format: yyyy-mm-dd+hh:mm).
ExpirationDate	The <i>Expiration Date</i> of the message (format: yyyy-mm-dd+hh:mm). Please find more information about the Expiration Date in Lifetime of a message.
Size	The <i>Size</i> of the message in bytes.

5.3.15.15 Meta

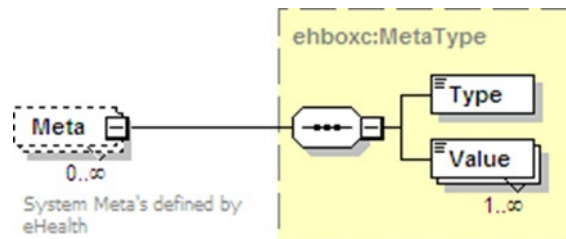

Field name	Description
Type	The type of the meta information (string minimum 1, maximum 250)
Value	A list of <i>Values</i> for this <i>Type</i> (string minimum 1, maximum 250)

5.3.15.16 Recipient

A *Recipient* contains all the information relative to your eHealthBox that received the message. This is very useful when you call upon the *GetAllEhboxesMessagesList* to identify which message was received by which eHealthBox. After all, two different eHealthBoxes could receive the same message. The message would then appear two times in *GetAllEhboxesMessagesList*.

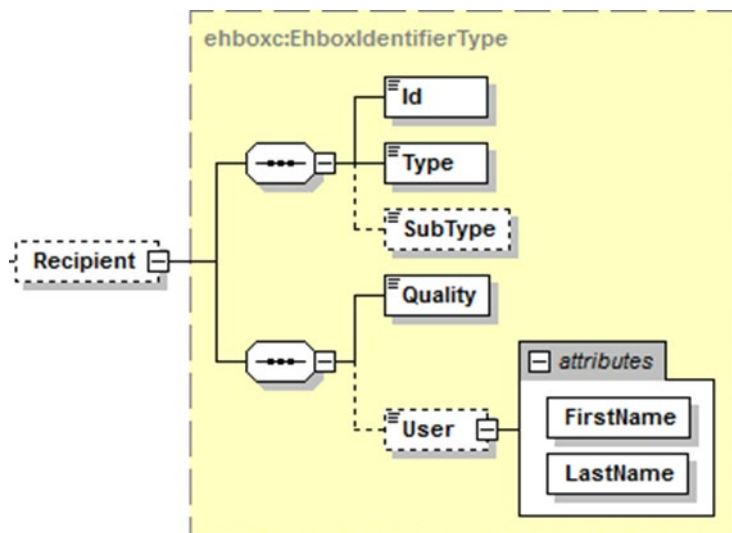

Field name	Description
ID	The recipient's identification number. This is a digital number representing an INSS, NIHII, FAMPH, or CBE. String.
Type	The recipient's ID type ("INSS", "NIHII", "FAMPH" or "CBE"). String.
Subtype (obsolete)	If the recipient is an organization, the <i>Subtype</i> allows (if necessary) further specification (such as "HOSPITAL" <i>SubType</i> for a Hospital <i>Quality</i> , or "GROUP" <i>SubType</i> for a Group <i>Quality</i>). String.
Quality	A <i>Quality</i> defines the recipient's eHealthBox. String (see reference 4 of eHealth platform documents)
User	An optional <i>User</i> (<i>FirstName</i> and <i>LastName</i>) can be added in the destination context. In case of a publication to an organization, this field is used to specify a member of this organization (e.g. a doctor working in a hospital), (string minimum 1, maximum 100).

5.3.15.17 Sender

A *Sender* element contains all the information relative to the *Sender* of the message.

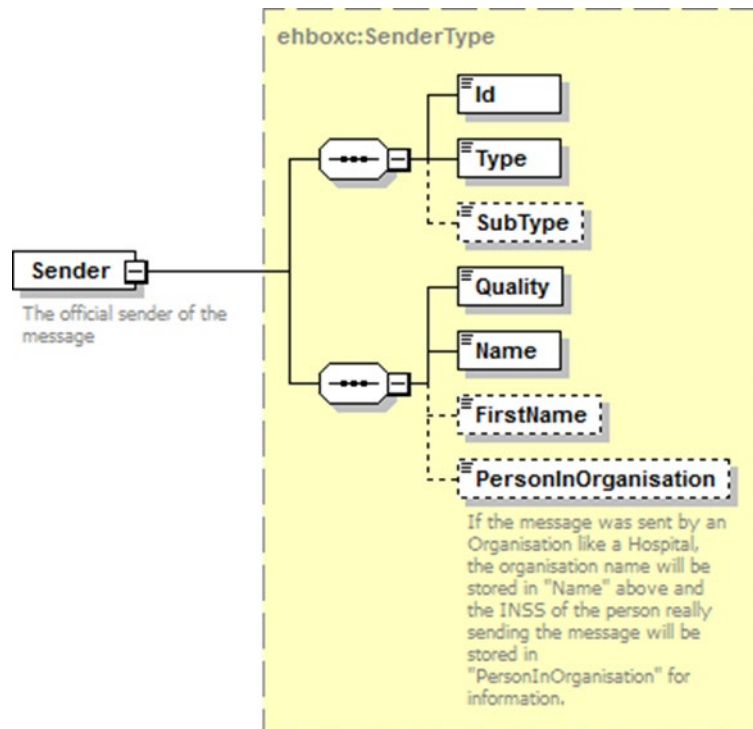

Field name	Description
ID	This is a digital number representing an INSS, NIHII, FAMPH, or CBE. This number is in a String format.
Type	The Sender ID type ("INSS", "NIHII", "FAMPH" or "CBE"). String.
Subtype (obsolete)	If the sender is an organization, the <i>Subtype</i> allows (if necessary) further specification (such as "HOSPITAL" <i>SubType</i> for a Hospital <i>Quality</i> , or "GROUP" <i>SubType</i> for a Group <i>Quality</i>). String.
Quality	A <i>Quality</i> defines the Sender eHealthBox. String
Name	Name of the Sender. String.
FirstName	FirstName of the Sender (optional). String.
PersonInOrganisation	If the message was sent by an organization like an hospital, the organization name will be stored in "Name" above and the INSS of the person really sending the message will be stored in "PersonInOrganisation" for information. String.

12345678912 box (ACKs)A particular box is the box identified as "12345678912". This is the 'no reply' box that the eHealth system uses to send the requested ACKNOWLEDGMENTS :

ID : 12345678912
 Type : INSS
 Quality : CITIZEN
 Name : Noreply

5.3.15.18 Substitute

A *Substitute* element contains all the information relative to the *Substitute* designated for a person;

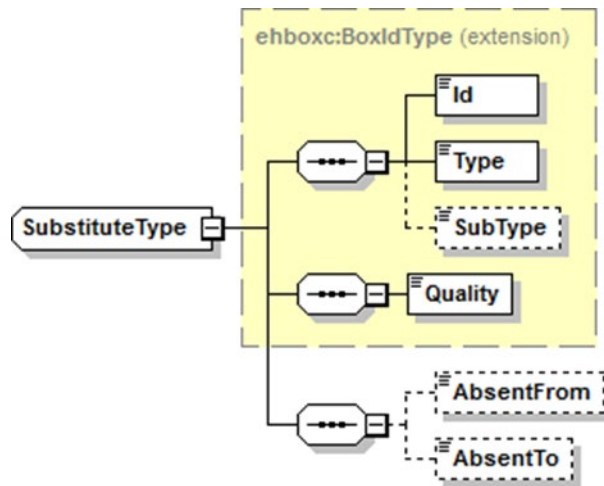

Field name	Description
ID	This is a digital number representing an INSS, NIHII, FAMPH, or CBE. String.
Type	The Sender ID type ("INSS", "NIHII", "FAMPH" or "CBE"). String.
Subtype (obsolete)	If the sender is an organization, the <i>Subtype</i> allows (if necessary) further specification (such as "HOSPITAL" <i>SubType</i> for a Hospital <i>Quality</i> , or "GROUP" <i>SubType</i> for a Group <i>Quality</i>). String.
Quality	A <i>Quality</i> defines the Sender eHealthBox. String
AbsentFrom	The <i>AbsentFrom</i> of the OoO. This date is inclusive. Ex. 2013-07-03+02:00
AbsentTo	The <i>AbsentTo</i> of the OoO. This date is inclusive. Ex. 2013-07-17+02:00

6. Risks and security

6.1 SOAP with attachments

The standard is used to transfer binary data via SOAP web services. SOAP with attachments is an older alternative to MTOM. SwA is used in combination with WS-Security.

The SwA specification describes how to send binary data separated from the SOAP body using multipart MIME messages.

SOAP Messages with attachments is a link to the W3C specification of the standard:

<http://www.w3.org/TR/SOAP-attachments>

Attachments Profile Version 1.0 is a link to the WS-I profile with clarifications and amendments to the SwA specification:

<http://www.ws-i.org/Profiles/AttachmentsProfile-1.0.html>

To keep a reference to the attachment from within the message payload, WS-I defined the simpleType swaRef:

<http://ws-i.org/profiles/basic/1.1/swaref.xsd>

The attachment data is no part of the message payload. Therefore, when you sign the SOAP body for secure transfer, the attachment data itself is not signed.

6.2 Security

6.2.1 Business security

In case the development adds a use case based on an existing integration, the eHealth platform must be informed at least one month in advance. A detailed estimate of the expected load is necessary to be able to ensure an effective capacity management.

When technical issues occur on the WS, the partner can obtain support from the contact centre (see Chap 3)

If the eHealth platform should find a bug or vulnerability in its software, the partner must update his application with the latest version of the software, within ten (10) business days.

If the partner finds a bug or vulnerability in the software or web service made available by the eHealth platform, he is obliged to contact and inform us immediately. He is not allowed, under any circumstances, to publish this bug or vulnerability.

6.2.2 Web service

Web service security used in this manner is in accordance with the common standards. Your call will provide:

- that the request is authenticated with the SAML security profile policy.
See the internet link **<http://docs.oasis-open.org/ws-sx/ws-securitypolicy/200702/>** for the specifications.
See also Use of the eHealth SSO solution **Error! Reference source not found.**(chapter 5.1.1) documents for a more detailed description of the SSO Access in the case of the eHealth platform.
- SSL one way.
an X.509 certificate. This certificate will contain the identifiers of the caller: INSS or NIHII number or CBE enterprise number. For more information on how to obtain a certificate please consult:
Dutch version: **<https://www.ehealth.fgov.be/ehealthplatform/nl/ehealth-certificaten>**
French version: **<https://www.ehealth.fgov.be/ehealthplatform/fr/certificats-ehealth>**
- the time-to-live of the message: one minute.
- the signature of the timestamp, body and binary security token. This will allow the eHealth platform to verify the integrity of the message and the identity of the message author.



In order to use the WS, an authorization from the eHealth platform is required.

6.2.3 Security policies to apply

We expect that you use SSL one way for the transport layer. As a WS security policy, we expect:

- a timestamp (the date of the request), with a Time to live of one minute. (If the message does not arrive during this minute, it shall not be treated).
- the signature with the certificate of
 - the timestamp (the one mentioned above)
 - the body (the message itself)
 - and the binary security token: an eHealth certificate or a SAML token issued by STS

This will allow the eHealth platform to verify the integrity of the message and the identity of the message author.

7. Test and release procedure

7.1 Procedure

This chapter explains the procedures for testing and releasing an application in acceptance or production.

7.1.1 Initiation

If you intend to use the eHealth service, please contact info@ehealth.fgov.be. The Project department will provide you with the necessary information and mandatory documents.

7.1.2 Development and test procedure

You have to develop a client (service consumer) in order to connect to our WS. Most of the required information about the integration is published on the eHealth portal site.

(<https://ehealth.fgov.be/ehealthplatform>)

In some cases, the eHealth platform provides you with test cases in order for you to test your client (service consumer) before releasing it in the acceptance environment.

7.1.2.1 Create test cases

Rules to access the Publication services are the same in test and in production. Access rules:

- to use the Consultation WS, the user must be part of one of the following profiles: **hospital, nurse, group, institution, doctor, and laboratory ...**
- authentication with a certificate

The development team of the eHealth platform configures all test cases.

7.1.2.2 Request a certificate

Prior to requesting the certificate, you need to have installed the latest version of *Java 1.6* and the *Belgium eID middleware*. You also need a smart-card reader and a Belgian eID.

Before requesting an eHealth certificate: please consult the chapter about the eHealth Certificates.

<https://www.ehealth.fgov.be/ehealthplatform/nl/ehealth-certificaten> (Dutch version)

<https://www.ehealth.fgov.be/ehealthplatform/fr/certificats-ehealth> (French version)

Depending on the user, you will need NIHII, INSS or CBE identification numbers in order to request the certificate.

7.1.2.3 Obtain SAML token

The usage of the STS (STS) and the structure of the exchanged xml-messages are described in the eHealth STS cookbook.

In the case of eHealthBox Publication WS, see document 3 of eHealth platform references in Chap 2.4.

7.1.3 Release procedure

When the development tests are successful, you can request to access the eHealth acceptance environment.

From the moment you start the integration and acceptance tests, the eHealth platform suggests testing during at least one month.

After the acceptance tests have been successfully completed, the partner sends his test results and performance results with a sample of the “eHealth request” and “eHealth answer” by email to his point of contact at the eHealth platform.



Then the eHealth platform and the partner agree on a release date. The eHealth platform prepares the connection to the production environment and provides the partner with the necessary information. During the release day, the partner provides the eHealth platform with feedback on the test and on the performance tests.

For further information and instructions, please contact: info@ehealth.fgov.be.

7.1.4 Operational follow-up

Once in production, the partner using the eHealth platform service for one of his applications will always perform test first in the acceptance environment before releasing any adaptations of his application in production. In addition, he will inform the eHealth platform on the progress and test period.

7.2 Test cases

This section describes a systematic process to test the Consultation WS.

The eHealth platform recommends performing tests for all of the following cases:

1. Consult your eHealthbox information with the method "getBoxInfo()".
2. Based on your tests cases defined previously for the Publication service, get the list of messages contained in your eHealthbox with the method "getMessagesList()". Execute this request on your inbox, sent box and on your bin.
3. Pick one of the "MessageIds" returned from your messages list and use it to get the full message with the method "getFullMessage()". Execute this request on a message from your inbox and sent box.
4. Use again your "MessageID" to move your received message from your inbox to your recycle bin with the method "moveMessage()".
5. Always consult the previous history of your message through a "MessageID" with the method "getMessageHistory()".
6. Use a "MessageID" from your sent box to consult the state of that message with "getMessageAcknowledgmentsStatus()".
7. Consult all your messages from all your eHealthboxes with "GetAllEhboxesMessagesList()". Execute this request on your inbox, sent box and on your bin.

8. Error and failure messages

8.1 Error Element Status Codes

Mail delivery system error codes originating from the application:

These error codes first indicate a problem with the message and or its recipients. This table can evolve.

Error code	Component	Description	Solution
700	Error	Unknown technical error	Call the Contact Center
701	Error	Business validation error	Check all fields, especially the recipients. The publication id is found under <i>PublicationId</i> .
702	Error	Duplicate publication id	Chose a new publication id, and send again. The duplicate publication id can be found under <i>PublicationId</i> .
703	Error	One or more recipients are invalid	Invalid recipients can be found under <i>Destination</i> .

8.2 Consultation Response Status Codes

Error codes originating from the eHealth platform:

These error codes indicate a problem in the sent arguments. This table can evolve.

Error code	Component	Description	Solution
100	*	SUCCESS	
806	* / MessageId	The specified MessageID is invalid; please verify that the Source and the MessageID are correct and that you can access it.	Is the MessageId correct? Is the message present in "Source"?
807	* / Start & EndIndex	EndIndex must be larger or equal to StartIndex; please correct StartIndex and EndIndex.	Is "EndIndex > StartIndex"?
808	* / Start & EndIndex	A maximum of 100 messages can be returned by request; please correct StartIndex and EndIndex.	Is "EndIndex - StartIndex + 1 <= 100"?
809	GetMessage-AcknowledgmentsStatus/MessageId	The specified MessageID is invalid; please verify that the MessageID is correct and that you are the sender.	Are you the sender of the message? Is the MessageId correct?
810	* / BoxId	The specified BoxId is invalid; please verify the data and that you can access it.	Can you normally access that eHealthBox?

			Double check if your SAML token contains all required attributes.
812	MoveMessage/ Source & Destination	You cannot move a message from your Inbox to your Sent box (even via recycle bin) and vice versa.	Is the message present in "Source"?
813	MoveMessage/ Source & Destination	Not all messages were moved successfully. Please verify for each message that the Source and the MessageID are correct. Also pay attention that a message in the recycle bin which was moved from the Inbox cannot be restored back to the Sent box and vice versa.	Some messages were not found in the folder specified in "Source". Some messages cannot be moved to "Destination".
815	DeleteMessage	Not all messages were deleted successfully. Please verify for each message that the Source and MessageID are correct.	Not deleted messages are listed in MessageID in the response.
820	InsertOoO	The period 01/07/2012 to 12/07/2012 is invalid because it overlaps another period.	Correct start or end date.
821	InsertOoO	The end of the period cannot be further than a year in the future.	Correct end date.
822	InsertOoO	The start date cannot be after the end date.	Correct start date.
823	InsertOoO	The start date cannot be in the past.	Correct start date.
824	InsertOoO	One or more substitutes cannot be chosen because they are absent.	Change one or more substitutes.
825	InsertOoO	The number of substitutes may not exceed 5.	Remove a substitute.
826	InsertOoO	The number of out of office for one eHealthBox may not exceed 10.	Delete and out of office.
827	InsertOoO	One or more substitutes are unknown or not correct, please correct them.	Correct one or more substitutes.
828	InsertOoO	The user is unknown or not correct, please correct him.	Re-authenticate.
829	InsertOoO	A valid substitute is a person, not an organization.	Change one or more substitutes.
830	InsertOoO	A person cannot be substitute for himself.	Change one or more substitutes.
840	DeleteOoO	One or more OoOld are invalid.	Verify the OoOld's.

8.3 Soap Fault Error Code

They contain the following attributes:



Field name	Descriptions
Id	Unique number identifying this message. If present, the ticket that was created for the client's request, leading to this error. When placed here this Id can be used to trace back the message from the request.
Origin	The component/party causing the error: consumer or provider, client or server.
Code	The error code
Message	A human readable message
Retry	An optional Boolean that indicates if it is worth resending the same request.
Contact	An optional field specifying a contact description.
Environment	The eHealth platform environment in which the error occurs: integration, acceptance or production.

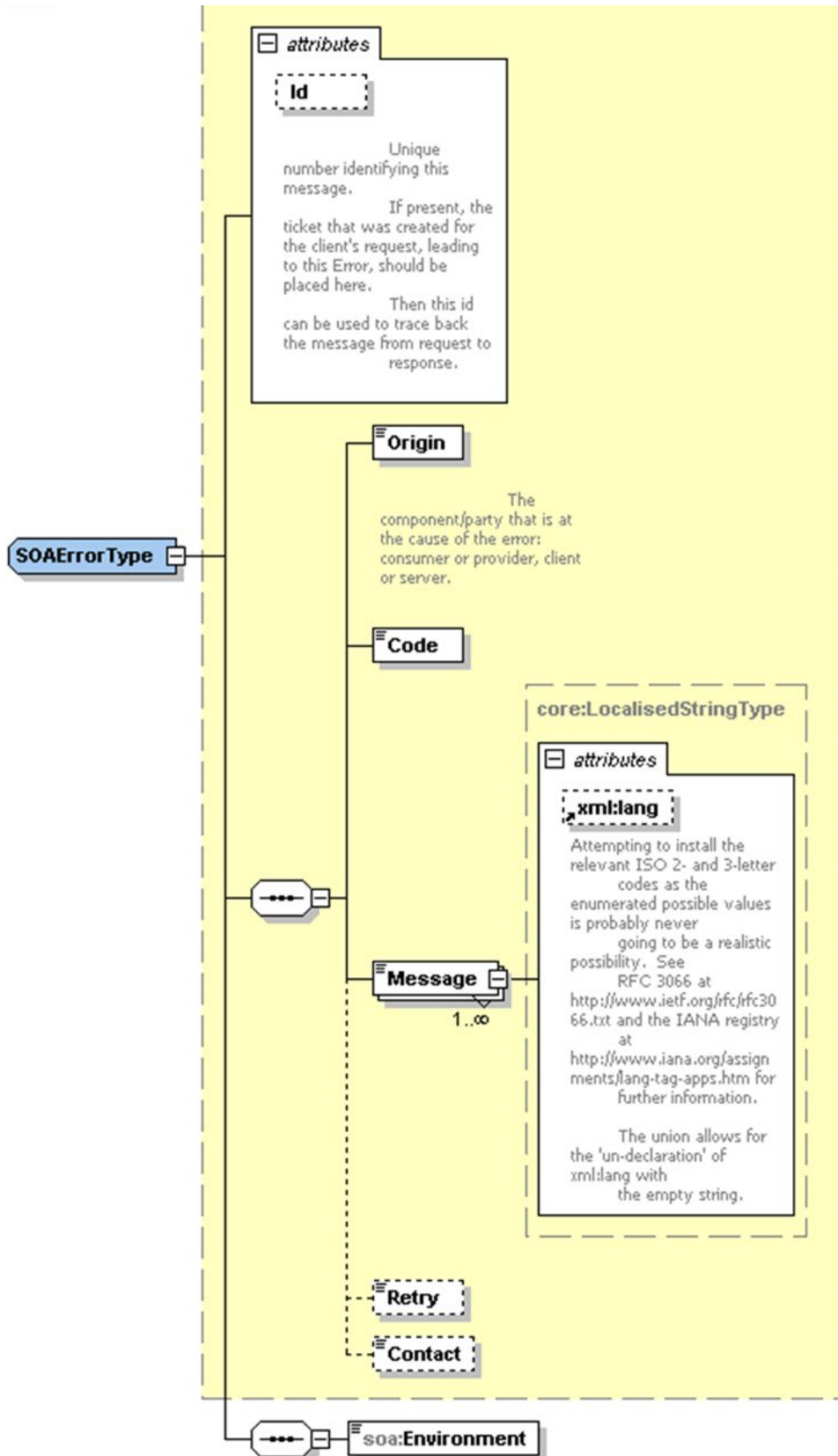

8.3.1 Schema Validation Errors

When invoking the WS, you must provide a valid XML.

Before executing any action, the eHealthBox system verifies if the XML is valid by running a validation check towards the SendMessageRequest XSD.

If the validation fails, a SOAP Fault is returned with the following code and message:

Code	Message
SOA-03006	XSD compliance failure

Example:

```
<?xml version="1.0" encoding="UTF-8"?>
<soapenv:Envelope xmlns:soapenv="http://schemas.xmlsoap.org/soap/envelope/">
<soapenv:Body xmlns:wsu="http://docs.oasis-open.org/wss/2004/01/oasis-200401-wss-wssecurity-utility-1.0.xsd" wsu:id="id-6">
<soapenv:Fault>
<faultcode>soapenv:Client</faultcode>
<faultstring>SOA-03006</faultstring>
<detail>
<soa:SystemError xmlns:soa="urn:be:fgov:health:errors:soa:v1" Id="5bbd8a2a-bb21-4cf8-99bc-8d52c18e2801">
<Origin>Consumer</Origin>
<Code>SOA-03006</Code>
<Message xml:lang="en">XSD compliance failure.</Message>
<soa:Environment>Production</soa:Environment>
</soa:SystemError>
</detail>
</soapenv:Fault>
</soapenv:Body>
</soapenv:Envelope>
```

8.3.2 Technical Errors

Technical errors are errors inherent to the internal working of the eHealth platform WS. These errors can also occur if the token used to call the WS is not valid.

They contain the standard SOAP Fault attributes.

The table provides the different codes and messages returned in a SOAP fault message:

Code	Message
SOA-00001	An internal error has occurred. Please refer to the Contact Center.

This list can evolve.

Example:

```
<?xml version="1.0" encoding="UTF-8"?>
<soapenv:Envelope xmlns:soapenv="http://schemas.xmlsoap.org/soap/envelope/">
<env:Body xmlns:env="http://schemas.xmlsoap.org/soap/envelope/">
<env:Fault>
```



```

<faultcode>soapenv:Server</faultcode>
<faultstring>SOA-00001</faultstring>
<detail>
<soa:SystemError Id="ec582704-d623-4b05-ab7f-98d5c9706dd1"
xmlns:soa="urn:be:fgov:health:errors:soa:v1">
<Origin>Server</Origin>
<Code>SOA-00001</Code>
<Message xml:lang="en">An internal error has occurred. Please contact service desk.</Message>
<soa:Environment>Production</soa:Environment>
</soa:SystemError>
</detail>
</env:Fault>
</env:Body>
</soapenv:Envelope>

```

8.4 Error codes originating from the eHealth platform

These error codes first indicate a problem in the arguments sent, or a technical error.

Error code	Component	Description	Solution
SOA-03001	Consumer	<i>This is the default error for content related errors in case no more details are known.</i>	Malformed message
SOA-03002	Consumer	<i>Message does not respect the SOAP standard.</i>	Message must be SOAP
SOA-03003	Consumer	<i>Message respects the SOAP standard, but body is missing.</i>	Message must contain SOAP body