

**DICS v4
Cookbook
Version 4.2**

This document is provided to you, free of charge, by the

eHealth platform

**Willebroekkaai 38 – 1000 Brussel
38, Quai de Willebroek – 1000 Bruxelles**

All are free to circulate this document with reference to the URL source.

Table of contents

Table of contents	2
1. Document management	5
1.1 Document history.....	5
2. Introduction	6
2.1 Goal of the service	6
2.2 Goal of the document	6
2.3 eHealth platform document references	6
2.4 External document references.....	6
2.5 Service history.....	7
3. Support	9
3.1 Helpdesk eHealth platform	9
3.1.1 Certificates.....	9
3.1.2 For issues in production	9
3.1.3 For issues in acceptance.....	9
3.1.4 For business issues	9
3.2 Status	9
4. Global overview	10
5. Step-by-step	11
5.1 Technical requirements.....	11
5.1.1 Security policies to apply	11
5.1.2 WS-I Basic Profile 1.1	11
5.1.3 Tracing	11
5.2 Process overview.....	11
5.2.1 Generic attributes.....	12
5.2.2 Response status.....	14
5.3 Operations.....	14
5.3.1 FindAmp	14
5.3.2 FindVmp	16
5.3.3 FindCompany.....	18
5.3.4 FindLegislationText	19
5.3.5 FindReimbursement	20
5.3.6 FindReferences	21
5.3.7 FindVmpGroup	22
5.3.8 FindVtm	23
5.3.9 FindCommentedClassification	24
5.3.10 FindCompoundingIngredient.....	25
5.3.11 FindCompoundingFormula	26
5.3.12 GetListOfVirtualMedicinalProducts	27
5.3.13 GetListOfVmpGroups.....	29



5.3.14	ConsultCompoundingFormulaType	30
5.3.15	SynonymType	31
5.3.16	GetListOfActualMedicinalProducts.....	31
5.3.17	GetListOfActualMedicinalProductPackages	32
5.3.18	FindAmp	33
5.3.19	FindNonMedicinalProduct.....	34
5.4	Request Types	35
5.4.1	FindByActualProduct	35
5.4.2	FindByPackage.....	36
5.4.3	FindByDmpp	37
5.4.4	FindByIngredient	37
5.4.5	FindByVirtualProduct.....	37
5.4.6	FindByGenericPrescriptionGroup.....	38
5.4.7	FindByCompany.....	38
5.4.8	FindByTherapeuticMoiety	38
5.4.9	FindByCommentedClassification	38
5.4.10	HasActualComponentWith	39
5.4.11	HasVirtualComponentWith	39
5.4.12	HasWadaClassification	39
5.4.13	ListConsultationRequestType	40
5.5	Response Types.....	41
5.5.1	ConsultAmpType	41
5.5.2	ConsultAmpComponentType	41
5.5.3	ConsultRealActualIngredientType	42
5.5.4	ConsultRealActualIngredientEquivalentType	42
5.5.5	ConsultAmpType	43
5.5.6	ConsultAmpComponentType	44
5.5.7	ConsultAmpComponentEquivalentType	45
5.5.8	ConsultSupplyProblemType	46
5.5.9	ConsultDerogationImportType.....	47
5.5.10	ConsultDmppType	48
5.5.11	ConsultVmpType	49
5.5.12	ConsultCommentedClassificationType	50
5.5.13	ConsultVmpGroupType	51
5.5.14	ConsultVtmType	51
5.5.15	ConsultVmpComponentType	52
5.5.16	ConsultVirtualIngredientType	53
5.5.17	ConsultCompanyType.....	54
5.5.18	ConsultLegalBasisType.....	55
5.5.19	ConsultRecursiveLegalReferenceType.....	56
5.5.20	ConsultRecursiveLegalTextType	57
5.5.21	ConsultFormalInterpretationType.....	58
5.5.22	ConsultReimbursementConditionType	58
5.5.23	ConsultReimbursementTermType.....	59

5.5.24	ConsultReimbursementContextType	60
5.5.25	ConsultCompoundingIngredientType.....	61
5.5.26	ConsultCompoundingFormulaType	61
5.5.27	SynonymType	62
5.5.28	ListConsultationResponseType.....	63
5.5.29	ConsultNonMedicinalProductType.....	64
6.	Risks and security.....	65
6.1	Risks & safety	65
6.2	Security	65
6.2.1	Business security	65
6.2.2	Web service	65
6.2.3	The use of username, password and token.....	65
7.	Test and release procedure.....	66
7.1	Procedure.....	66
7.1.1	Initiation	66
7.1.2	Development and test procedure	66
7.1.3	Release procedure.....	66
7.1.4	Operational follow-up	66
7.2	Test cases	66
8.	Error and failure messages.....	67
8.1	Business errors.....	67
8.2	Technical errors.....	68

To the attention of: “IT expert” willing to integrate this web service.



1. Document management

1.1 Document history

Version	Date	Author	Description of changes / remarks
1.	02/08/2016	eHealth platform	Initial version
4.0	07/12/2017	Smals	FINAL - validated by eHealth-platform
4.1	20/03/2018	eHealth platform	Lay-out and links
4.2	08/08/2022	eHealth platform	§ 2.4 External document references (added) § 3 Support (updated) § 5.1.2 WS-I Basic profile (added) § 5.1.3 Tracing (added)

2. Introduction

2.1 Goal of the service

The Authentic Source of Medicines (SAM) is system gathering information about drugs authorized on the Belgian market and their reimbursements. Many responsible public institutions manage the information: BCPI¹, FAMHP², NIHDI³, FPS Economy⁴ and APB⁵.

The main goal of the project is to allow the prescribers and insurance institutions to electronically communicate information and decisions in order to accelerate the reimbursement process for the patient.

The information in the SAM is public.

DICS (Drugs Information Consultation System) v4 is the consultation web service for SAM v2.

2.2 Goal of the document

This document is not a development or programming guide for internal applications. Instead, it provides functional and technical information and allows an organization to integrate and use the eHealth platform service.

However, in order to interact in a smooth, homogeneous and risk controlled way with a maximum of partners, these partners must commit to comply with the requirements of specifications, data format and release processes of the eHealth platform as described in this document.

Technical and business requirements must be met in order to allow the integration and validation of the eHealth platform service in the client application.

2.3 eHealth platform document references

In the technical library on the portal of the eHealth platform, you can find all the referenced documents.⁶ These versions or any following versions can be used for the eHealth platform service.

ID	Title	Version	Date	Author
1	Glossary.pdf			eHealth platform
2	Reimbursement Law - Rules and expressions	1.5	2017-06-23	RIZIV/INAMI

2.4 External document references

All documents can be found through the internet. They are available to the public, but not supported by the eHealth platform.

¹ <http://www.cbip.be/>.

² <http://www.fagg-afmps.be/en/famhp/>.

³ <http://www.inami.fgov.be/fr/Pages/default.aspx>.

⁴ <http://economie.fgov.be/>

⁵ <http://www.apb.be/>

⁶ <https://ehealth.fgov.be/ehealthplatform>



ID	Title	Source	Date	Author
1	Basic Profile Version 1.1	http://www.ws-i.org/Profiles/BasicProfile-1.1-2004-08-24.html	24/08/2004	Web Services Interoperability Organization

2.5 Service history

This chapter contains the list of changes made to the service with respect to the previous version.

Previous version	Previous release date	changes
1	2015-01-08	First version, based on the SAM CIVICS interface.
2	2016-07-31	Complete rework: new backend, new interface based on consultation of 5 domains.
3	2017-03-19	Some fields in the response moved, some fields were added. All in all minor changes, but not backwards compatible. Addition of Find Compounding operations.
4	2017-11-26	<p>Changes:</p> <ol style="list-style-type: none"> 1) Pricing Range / Unit / Slice FindReimbursementResponse/ReimbursementContexts/PricingRange replaced by FindReimbursementResponse/ReimbursementContexts/PricingUnit FindReimbursementResponse/ReimbursementContexts/PricingSlice 2) CopaymentSupplement New field FindReimbursementResponse/ReimbursementContexts/CopaymentSupplement 3) Attachment Mandatory flag New field FindLegislationTextResponse/LegalBasis/LegalReference//FormalInterpretation/ReimbursementCondition/Attachment/Mandatory 4) New Reference Distributor in AMPP FindAmpResponse/Amp/Ampp/DistributorActorNr 5) CommentedClassification is now a ConsultTextType ConsultCommentedClassificationTreeType/Url 6) New field AdditionalInformation in SupplyProblem FindAmpResponse/Amp/Ampp/SupplyProblem/AdditionalInformation 7) DerogationImport now directly under AMPP FindAmpResponse/Amp/Ampp/SupplyProblem/DerogationImport moved to FindAmpResponse/Amp/Ampp/DerogationImport <p>New operations:</p>

		<ol style="list-style-type: none">1) ListConsultation2) FindAmp3) FindNonMedicinalProduct
--	--	---

3. Support

3.1 Helpdesk eHealth platform

3.1.1 Certificates

In order to access the secured eHealth platform environment you have to obtain an eHealth platform certificate, used to identify the initiator of the request. In case you do not have one, please consult the chapter about the eHealth Certificates on the portal of the eHealth platform

- <https://www.ehealth.fgov.be/ehealthplatform/nl/ehealth-certificaten>
- <https://www.ehealth.fgov.be/ehealthplatform/fr/certificats-ehealth>

For technical issues regarding eHealth platform certificates

- Acceptance: acceptance-certificates@ehealth.fgov.be
- Production: support@ehealth.fgov.be

3.1.2 For issues in production

eHealth platform contact centre:

- Phone: 02 788 51 55 (on working days from 7 am till 8 pm)
- Mail: support@ehealth.fgov.be
- Contact Form :
 - <https://www.ehealth.fgov.be/ehealthplatform/nl/contact> (Dutch)
 - <https://www.ehealth.fgov.be/ehealthplatform/fr/contact> (French)

3.1.3 For issues in acceptance

Integration-support@ehealth.fgov.be

3.1.4 For business issues

- regarding an existing project: the project manager in charge of the application or service
- regarding a new project or other business issues: info@ehealth.fgov.be

3.2 Status

The website <https://status.ehealth.fgov.be> is the monitoring and information tool for the ICT functioning of the eHealth services that are partners of the Belgian eHealth system.



4. Global overview

The SAM v2 database is divided in four major domains:

Actual Medicine: information about actual drug products and the related packages authorized on the Belgian market. The FAMHP is responsible for monitoring this information. BCPI and NIHDI can register additional information on a drug product created by the FAMHP.

Reimbursement: information about the reimbursement of a delivered drug package managed by the NIHDI.

Reimbursement Law: information about the legislation that describes the conditions and terms of the reimbursement of a drug package, i.e. Chapter IV describing the conditions for reimbursement of specialties, which are refundable through a medical advisor's agreement. This part is managed by the NIHDI.

Virtual Medicine: extra information about the drug products for prescription managed by the BPCI.

Additionally, 3 minor domains containing simpler elements are published as well:

Company: information about the pharmaceutical company that is responsible for delivered drug packages. The FAMHP is responsible for monitoring this information;

Compounding: Contains the names, synonyms and CNK codes for ingredients and formulae prepared by the pharmacist. These are used as source of information for electronic prescriptions. The information is published by APB.

Non-medicinal products: information about non-medicinal products that can be part of a prescription nonetheless. The information is published by APB.

5. Step-by-step

5.1 Technical requirements

5.1.1 Security policies to apply

We expect that you use SSL one way for the transport layer.

As web service security policy, we expect:

- A timestamp (the date of the request), with a Time to live of one minute. If the message does not arrive during this minute, it shall not be treated.
- The signature with the certificate of
 - the timestamp, (the one mentioned above)
 - the body (the message itself)
 - and the binary security token: any valid eHealth certificate

This will allow eHealth to verify the integrity of the message and the identity of the message author.

A document explaining how to implement this security policy can be obtained at the eHealth platform.

5.1.2 WS-I Basic Profile 1.1

Your request must be WS-I compliant (See Chap 2.4 - External Document Ref).

5.1.3 Tracing

To use this service, the request SHOULD contain the following two http header values (see RFC

<https://datatracker.ietf.org/doc/html/rfc7231#section-5.5.3>):

1. User-Agent: information identifying the software product and underlying technical stack/platform. It MUST include the minimal identification information of the software such that the emergency contact (see below) can uniquely identify the component.
 - a. Pattern: {minimal software information}/{version} {minimal connector information}/{connector-package-version}
 - b. Regular expression for each subset (separated by a space) of the pattern: `[[a-zA-Z0-9-\\]]*\\V[0-9azA-Z-_*]`
 - c. Examples:
User-Agent: myProduct/62.310.4 Technical/3.19.0
User-Agent: Topaz-XXXX/123.23.X freeconnector/XXXXX.XXX
2. From: email-address that can be used for emergency contact in case of an operational problem.
Examples:
From: info@mycompany.be

5.2 Process overview

The DICS v4 service has the following endpoints:

- Integration environment: <https://services-int.ehealth.fgov.be/Dics/v4>
- Acceptance environment: <https://services-acpt.ehealth.fgov.be/Dics/v4>
- Production environment: <https://services.ehealth.fgov.be/Dics/v4>



Text search

Many objects have multiple searchable names. The Consultation service searches all name fields with the input of an 'Any Name Part' field in the request. Only the beginning of the name is searched: you can provide a partial name. All objects where at least one name field matches are returned in the result.

E.g.: a search string 'Par' matches 'Paracetamol' and 'Paroxetin', but not 'Heparin'.

5.2.1 Generic attributes

The following attributes are generic and appear in many entities. It will be indicated further when it has to be specified and what value it can contain.

Notes: to reduce redundancy in the document

- The optionality is not repeated in the description tables. The optionality can be visually determined. A dashed line means an optional field; a full line means a required field.
- For all fields that contain in separate subfields translations:
 - These fields are translated in French, Dutch, German and English.
 - French and Dutch versions are mandatory and all others are optional.
 - The ConsultTextType contains at least two Text elements with a corresponding xml:lang attribute.

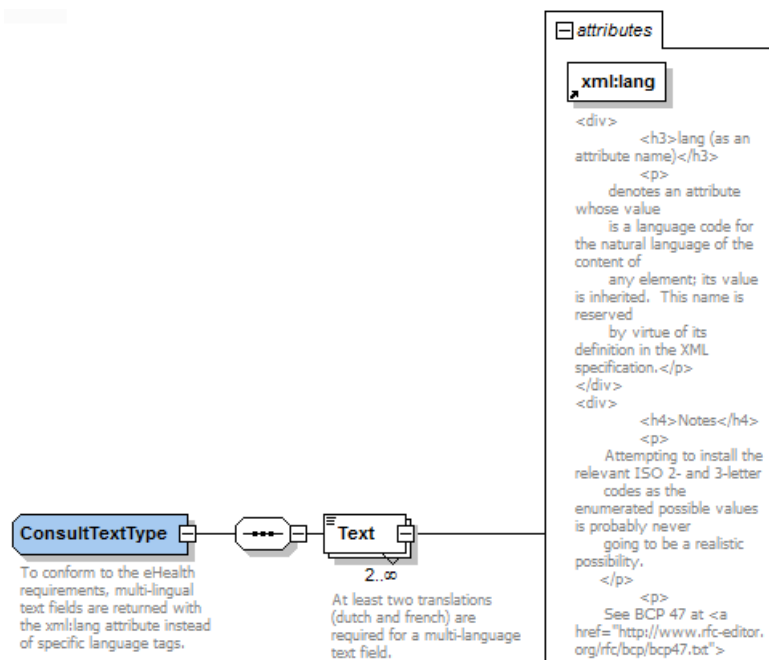

All Find*Requests define the same attributes **lang** and **SearchDate**. To conform to eHealth SOA standards, they also define the attributes **Id** and **IssueInstant**

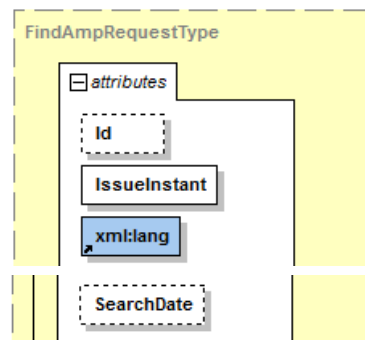

Name	Description
lang	Required. Can be NI, FR, EN or DE. When searching in text fields (such as a Product name), the search is limited to fields of the selected language. The result will contain the entire object however, with text in all available languages.
SearchDate	Optional. Search SAM situation on a date different from today. This search will make use of the functional history of SAM. If the data for the given period were corrected between the searched date and now, the corrected data will be returned.
Id	Optional All SOA Service Consumers SHOULD set an Id but it is not mandatory. The Id SHOULD be unique on a per request base to facilitate tracing on both client and server side.
IssueInstant	Required Time of the service call.

To conform to eHealth SOA standards, all responses define an additional attribute **InResponseTo**

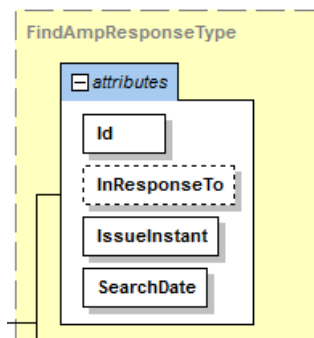

Name	Description
InResponseTo	Optional. If available, InResponseTo contains the Id attribute of the Request.

5.2.2 Response status

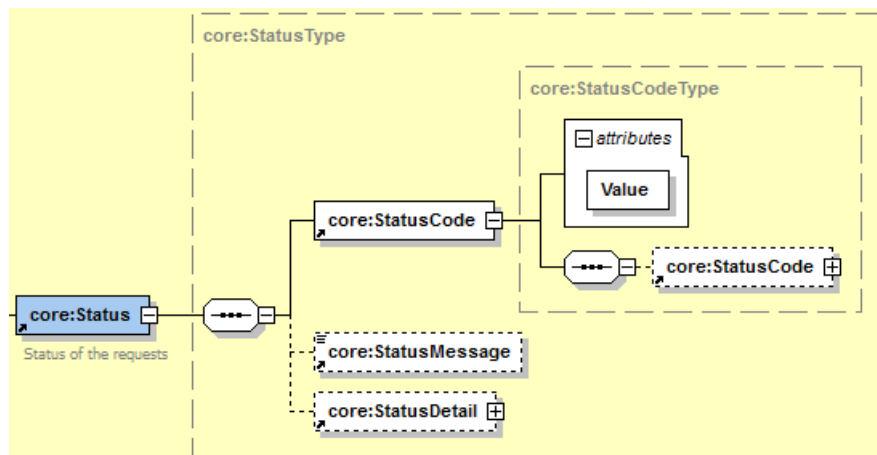

As part of eHealth SOA standards, all responses include an element Status

The Status element of the Response contains a *StatusCode*.

- A StatusCode is recursive and can therefore contain an embedded StatusCode to define a sublevel StatusCode.
- Each StatusCode must have a value attribute.
- There must be at least a level 1 StatusCode.

Level 1 *StatusCode* MUST be one of the following values:

URI	Description
urn:be:fgov:health:2.0:status:Success	everything OK
urn:be:fgov:health:2.0:status:Requester	error caused by client (consumer)
urn:be:fgov:health:2.0:status:Responder	error caused by server (provider)

See section 8.1 Business errors for a detailed list of level 2 StatusCodes values and descriptions.

5.3 Operations

5.3.1 FindAmp

Find an AMP based on one or more criteria.

5.3.1.1 FindAmpRequest

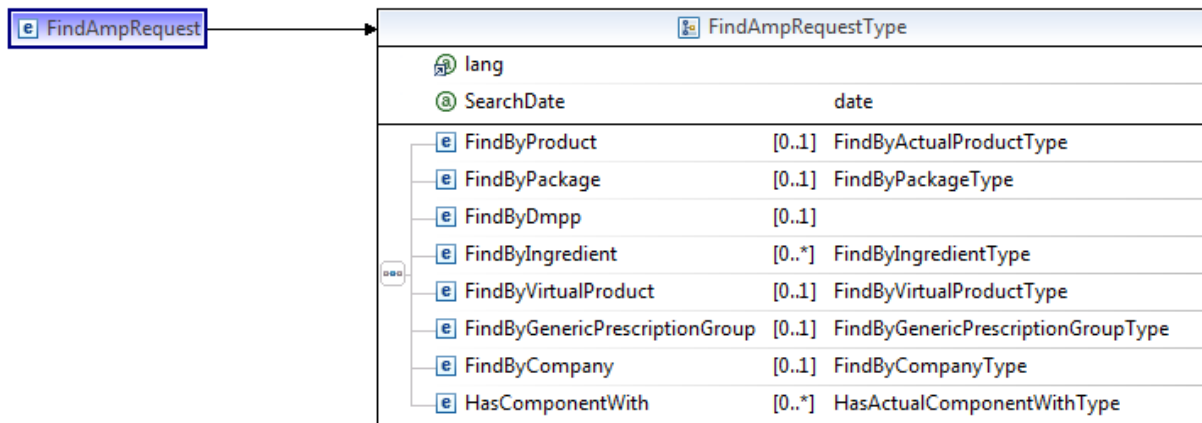

Field name	Description
FindByProduct	Search by AMP code or a combination of name parts. All AMPs matching all name parts are returned.
FindByPackage	Search an AMP based on an AMPP identifier or any package name part. If an AMPP matches, the complete AMP is returned.
FindByDmpp	Search an AMP based on a DMPP identifier. All products with packages linked to the given DMPP are returned.
FindByIngredient	Search an AMP based on ingredients. All AMPs containing all requested ingredients are returned.
FindByVirtualProduct	Search an AMP based on corresponding VMP code or name. For more complex searches, first call the FindVmp service to get the VMPCodes.
FindByGenericPrescriptionGroup	Search an AMP based on corresponding Generic Prescription Group code or name.
FindByCompany	Search an AMP based on the distributing company.
HasComponentWith	Must be combined with at least one FindBy element. Only those AMPs who have a component matching these attributes will be returned.

5.3.1.2 FindAmpResponse

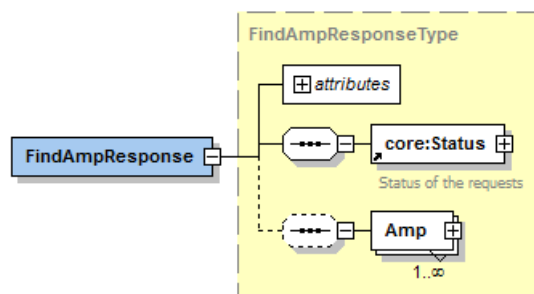

Attribute of FindAmpResponse	
Name	Description
SearchDate	Date of the consultation

5.3.1.3 Example

Request:

```

<urn:FindAmpRequest          Id="_1"          IssueInstant="2017-11-
28T15:44:04.902+01:00" SearchDate="2017-10-18" xml:lang="nl">
  <FindByPackage>
    <AnyNamePart>abilify</AnyNamePart>
  </FindByPackage>
</urn:FindAmpRequest>

```

Reply:

Too long for this document.

5.3.2 FindVmp

Find a VMP based on one or more criteria



5.3.2.1 Input arguments

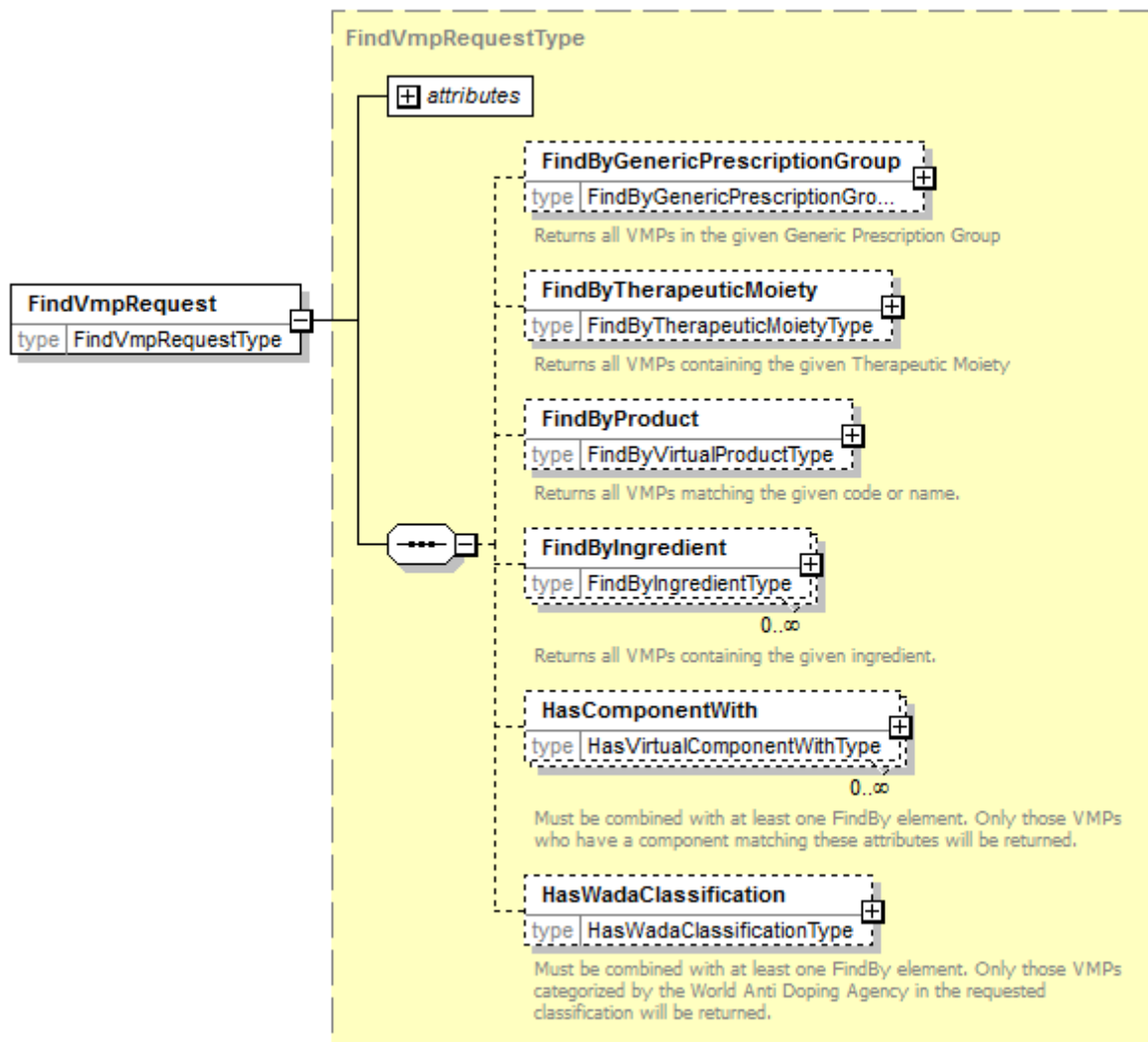

Field name	Description
FindByGenericPrescriptionGroup	Returns all VMPs in the given Generic Prescription Group
FindByTherapeuticMoiety	Returns all VMPs containing the given Therapeutic Moiety
FindByProduct	Returns all VMPs matching the given code or name.
FindByIngredient	Returns all VMPs containing the given ingredient.
HasComponentWith	Must be combined with at least one FindBy element. Only those VMPs who have a component matching these attributes will be returned.
HasWadaClassification	Must be combined with at least one FindBy element. Only those VMPs categorized by the World Anti-Doping Agency in the requested classification will be returned.

5.3.2.2 Output arguments

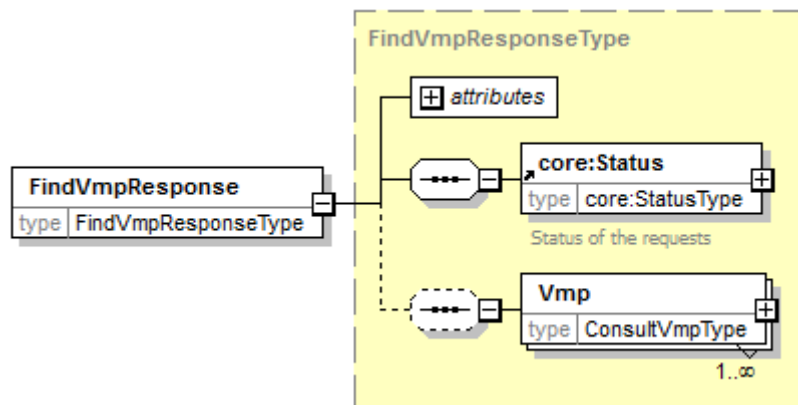

5.3.3 FindCompany

5.3.3.1 Input arguments

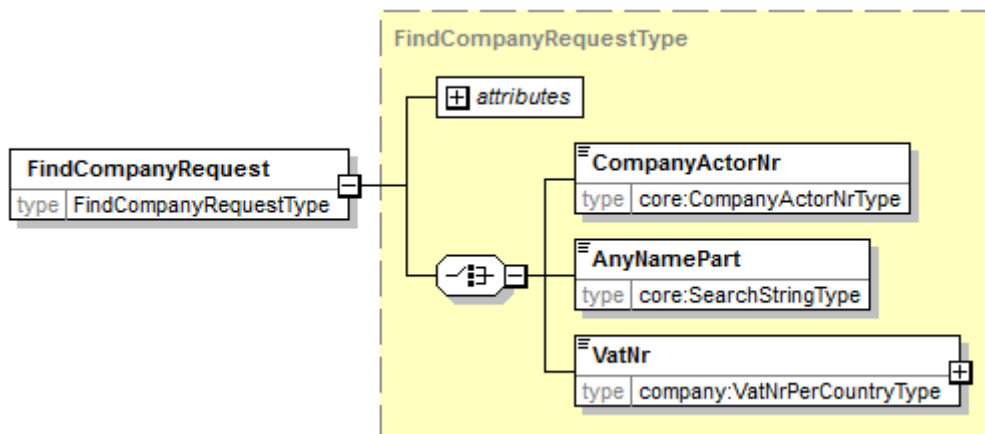

Field name	Description
CompanyActorNr	The unique identifier attributed to the company by the FAMHP
AnyNamePart	Returns the companies where any of the names starts with the given string
VatNr	Returns the company identified by the given Vat number.

5.3.3.2 Output arguments

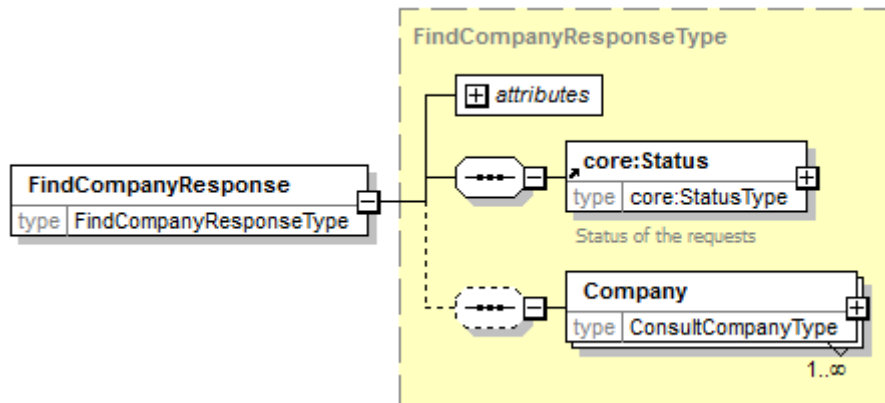

5.3.4 FindLegislationText

5.3.4.1 Input arguments

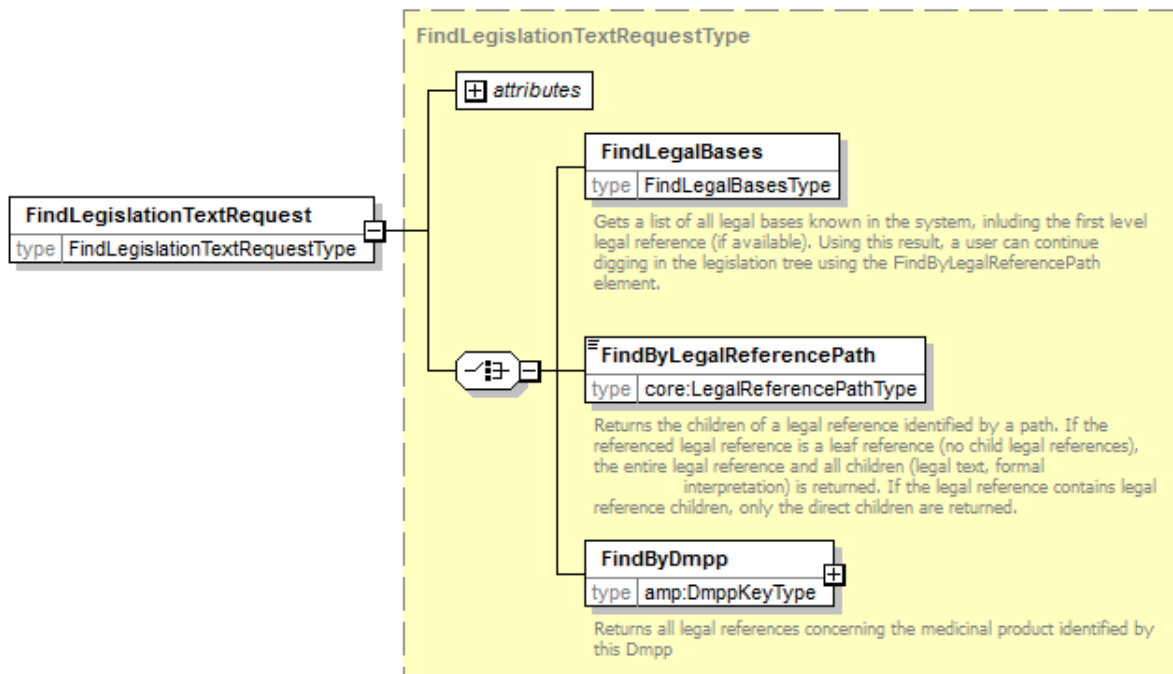

Field name	Description
FindLegalBases	Gets a list of all legal bases known in the system, including the first level legal reference (if available). Using this result, a user can continue digging in the legislation tree using the FindByLegalReferencePath element.
FindByLegalReferencePath	Returns the children of a legal reference identified by a path. If the referenced legal reference is a leaf reference (no child legal references), the entire legal reference and all children (legal text, formal interpretation) is returned. If the legal reference contains legal reference children, only the direct children are returned.
FindByDmpp	Returns all legal references concerning the medicinal product identified by this Dmpp

5.3.4.2 Output arguments

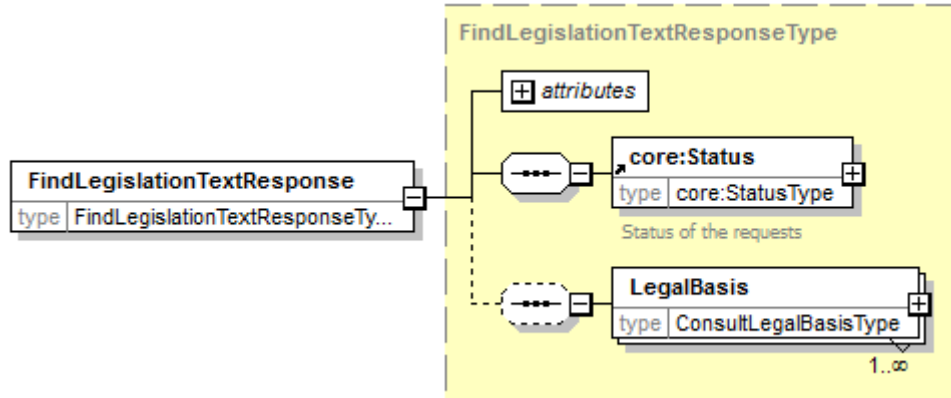

5.3.5 FindReimbursement

5.3.5.1 Input arguments

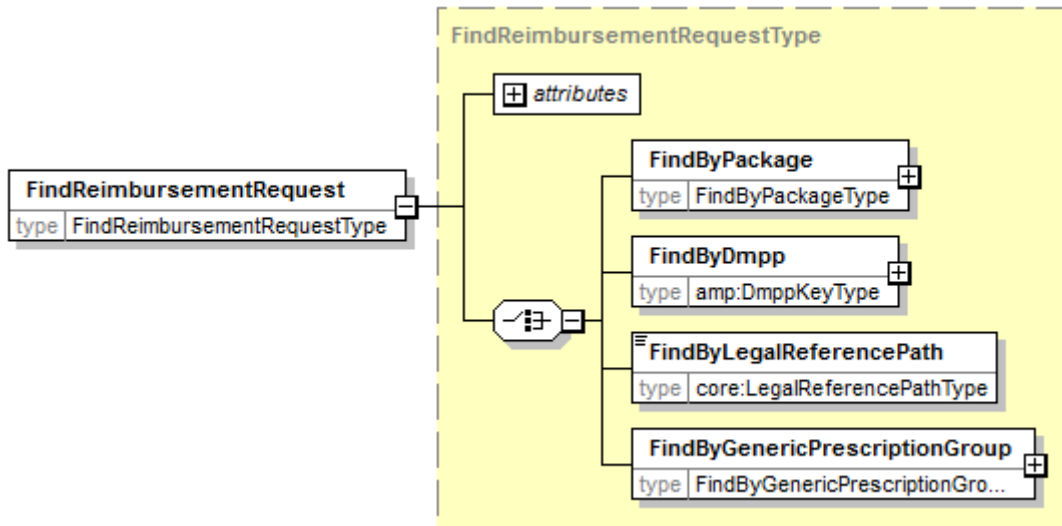

Field name	Description
FindByPackage	Find Reimbursement Contexts based on the concerned packages.
FindByDmpp	Find Reimbursement Contexts based on a DMPP (CNK code)
FindByLegalReferencePath	Find Reimbursement Contexts based on a Legal Reference Path
FindByGenericPrescriptionGroup	Find Reimbursement Contexts based on a Generic Prescription Group

5.3.5.2 Output arguments

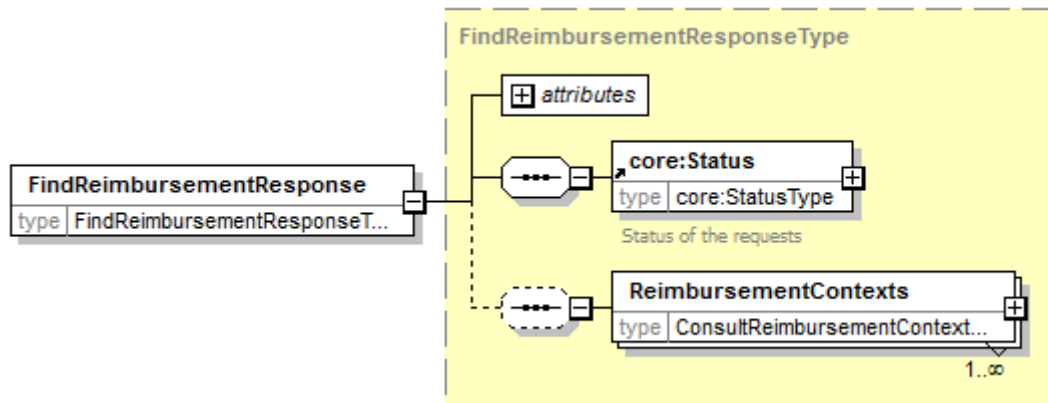

5.3.6 FindReferences

5.3.6.1 Input arguments

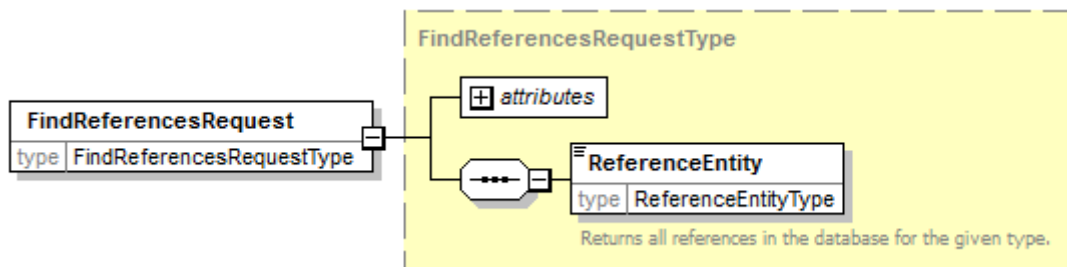

Field name	Description
ReferenceEntity	<p>Returns all references in the database for the given type.</p> <p>Possible types:</p> <ul style="list-style-type: none"> • AtcClassification • DeliveryModus • DeliveryModusSpecification • DeviceType • PackagingClosure • PackagingMaterial • PackagingType • PharmaceuticalForm • RouteOfAdministration • Substance • NoSwitchReason • VirtualForm • Wada • NoGenericPrescriptionReason • Appendix • FormCategory • Parameter • ReimbursementCriterion • StandardForm • StandardRoute • StandardSubstance • StandardUnit

5.3.6.2 Output arguments

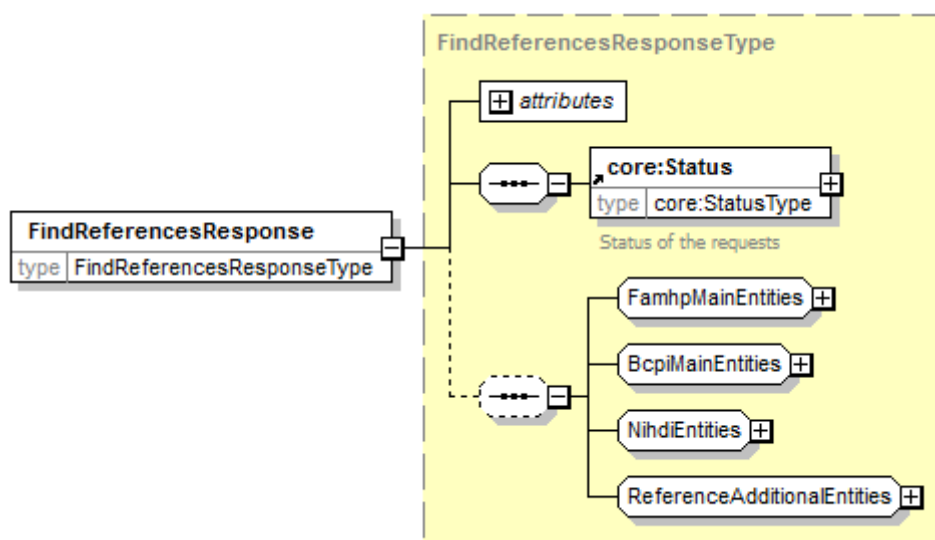

Returns only the requested fields.

5.3.7 FindVmpGroup

Since DICS v3

5.3.7.1 Input arguments

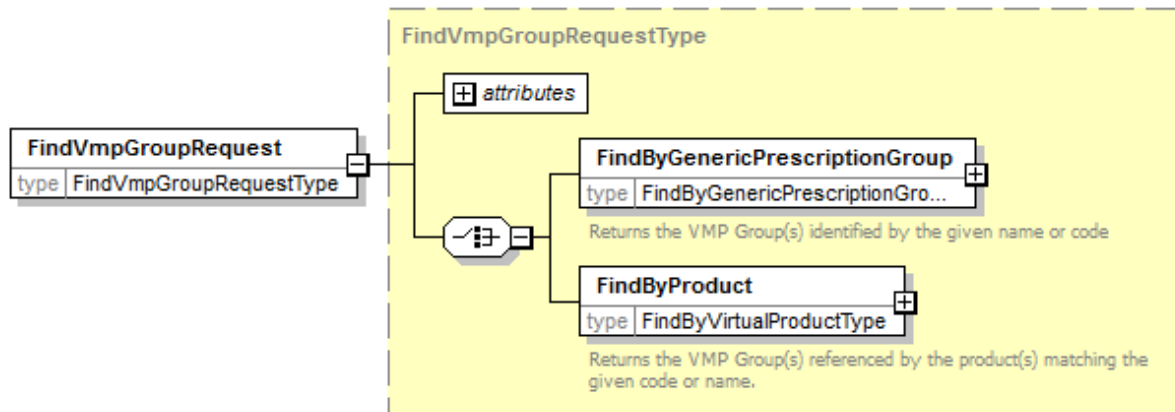

Field name	Description
FindByGenericPrescriptionGroup	Returns the VMP Group(s) identified by the given name or code
FindByProduct	Returns the VMP Group(s) referenced by the product(s) matching the given code or name.

5.3.7.2 Output arguments

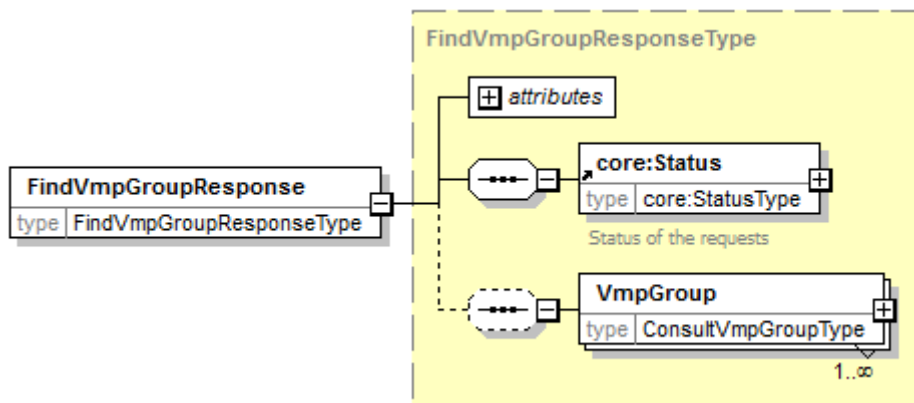

5.3.8 FindVtm

Since DICS v3

5.3.8.1 Input arguments

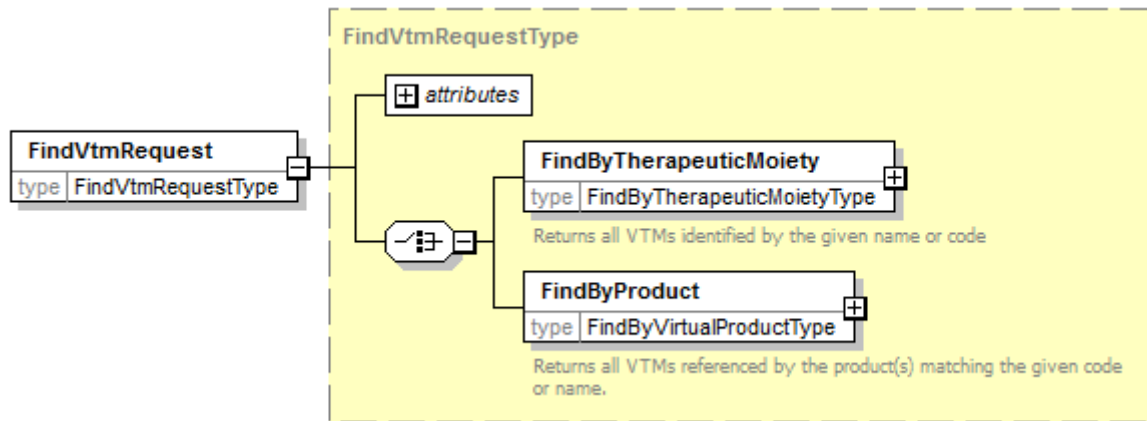

Field name	Description
FindByTherapeuticMoiety	Returns all VTMs identified by the given name or code
FindByProduct	Returns all VTMs referenced by the product(s) matching the given code or name.

5.3.8.2 Output arguments

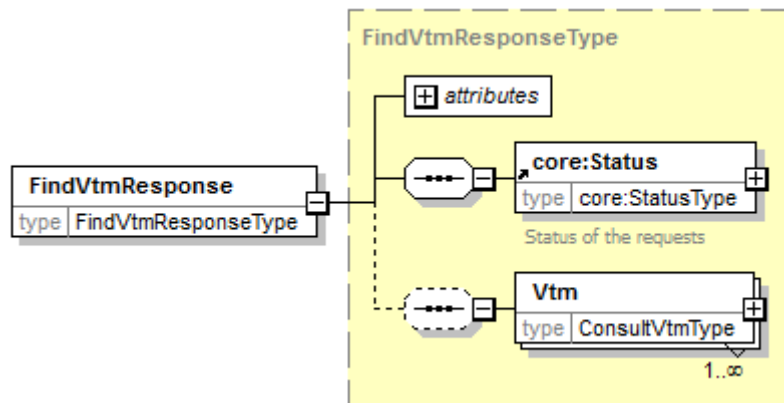

5.3.9 FindCommentedClassification

Since DICS v3

5.3.9.1 Input arguments

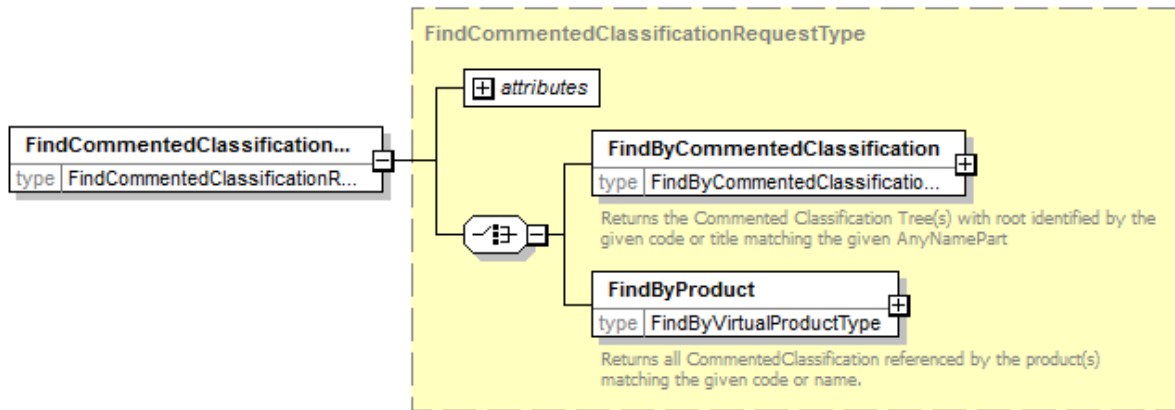

Field name	Description
FindByCommentedClassification	Returns the Commented Classification Tree(s) with root identified by the given code or title matching the given AnyNamePart
FindByProduct	Returns all CommentedClassification referenced by the product(s) matching the given code or name.

5.3.9.2 Output arguments

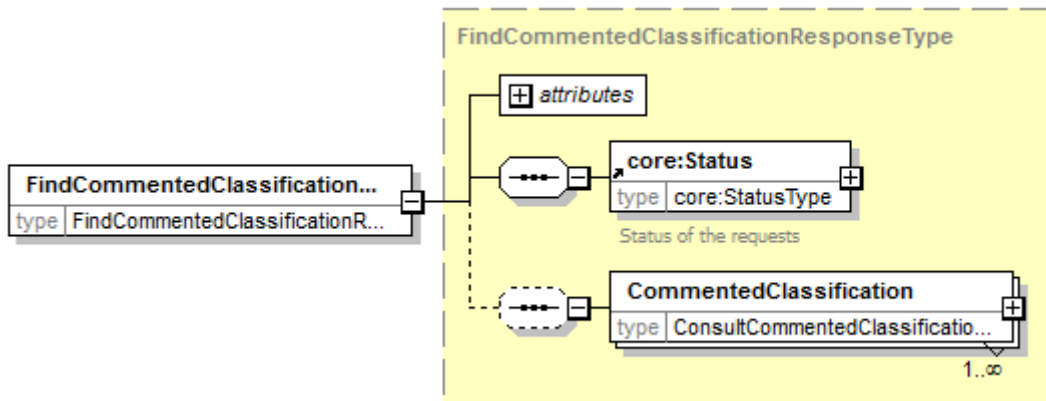

5.3.10 FindCompoundingIngredient

Since DICS v3

5.3.10.1 Input arguments

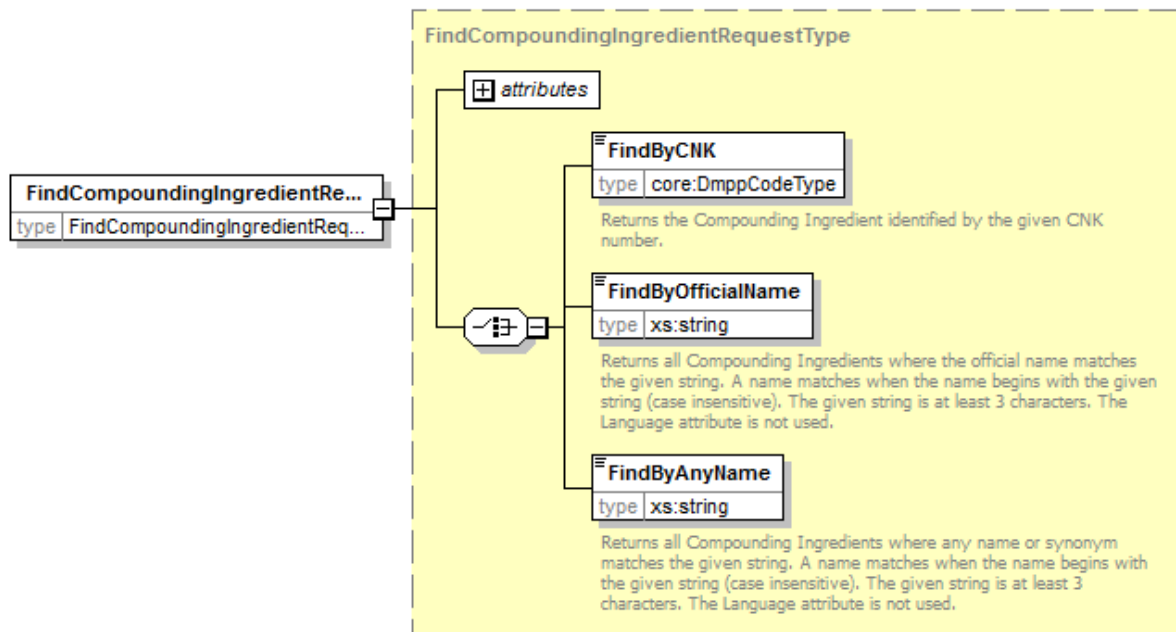

Field name	Description
FindByCNK	Returns the Compounding Ingredient identified by the given CNK number.
FindByOfficialName	Unused – Notion of official name no longer exists in Compounding. Returns the same result as FindByAnyName
FindByAnyName	Returns all Compounding Ingredients where any name or synonym matches the given string. A name matches when the name begins with the given string (case insensitive). The given string is at least 3 characters. The Language attribute is not used.

5.3.10.2 Output arguments

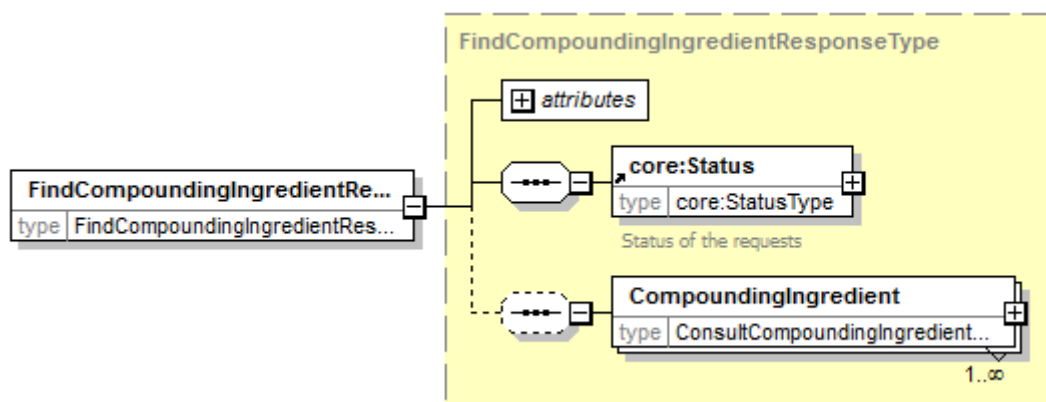

5.3.11 FindCompoundingFormula

Since DICS v3

5.3.11.1 Input arguments

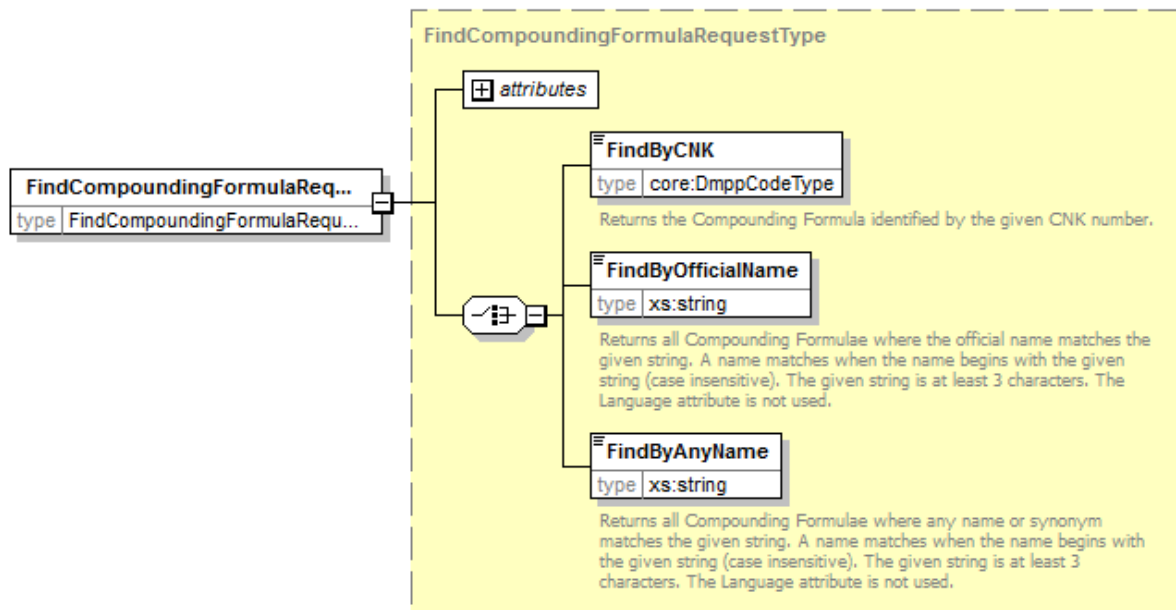

Field name	Description
FindByCNK	Returns the Compounding Formula identified by the given CNK number.
FindByOfficialName	Unused – Notion of official name no longer exists in Compounding. Returns the same result as FindByAnyName
FindByAnyName	Returns all Compounding Formulae where any name or synonym matches the given string. A name matches when the name begins with the given string (case insensitive). The given string is at least 3 characters. The Language attribute is not used.

5.3.11.2 Output arguments

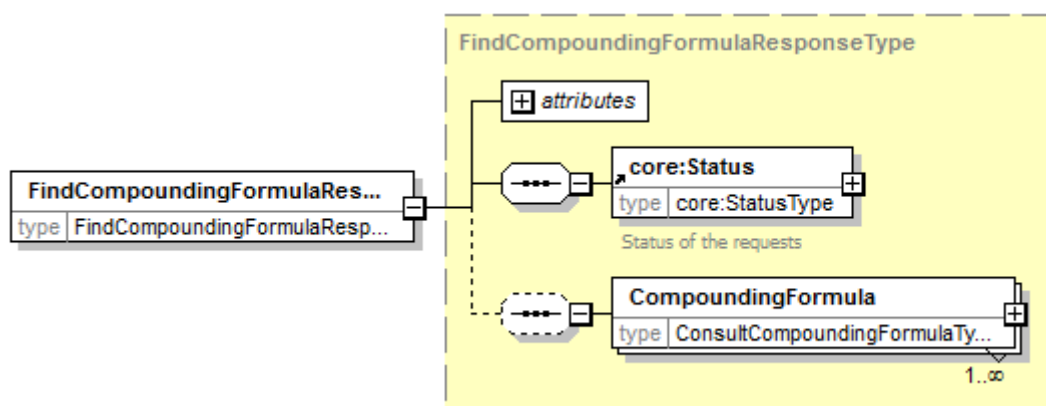

5.3.12 GetListOfVirtualMedicinalProducts

Since DICS v4

The four GetListOf operations can be used to synchronously get a list of all items in the SAM database. For each of the four types, a reduced list is returned using pagination. Only the name(s) and codes are returned. For a full view, the other consult operations can be used.

5.3.12.1 Input arguments

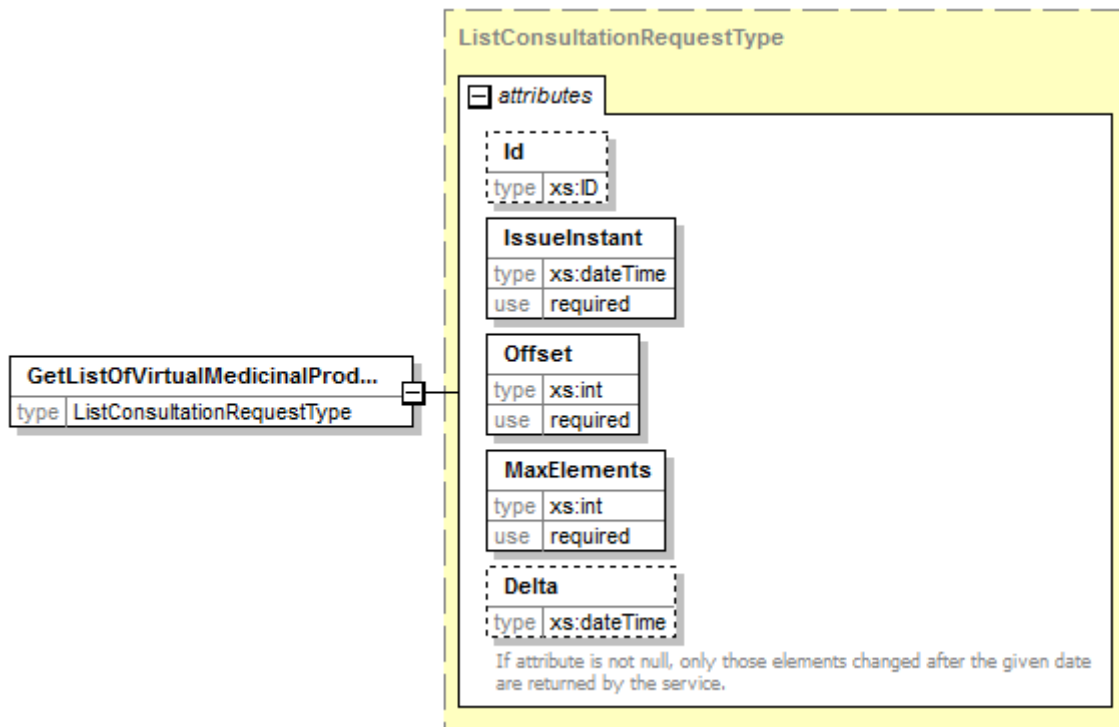

Field name	Description
Id	See 5.2.1 Generic attributes
IssueInstant	See 5.2.1 Generic attributes
Offset	Used for pagination. Returns the number of results defined in MaxElements, starting from the specified Offset. The first result has index 0. Default: 0
MaxElements	Used for pagination. Returns the number of results defined in MaxElements, starting from the specified Offset. The first result has index 0. Default: 100
Delta	If attribute is not null, only those elements changed after the given date are returned by the service.

5.3.12.2 Output arguments

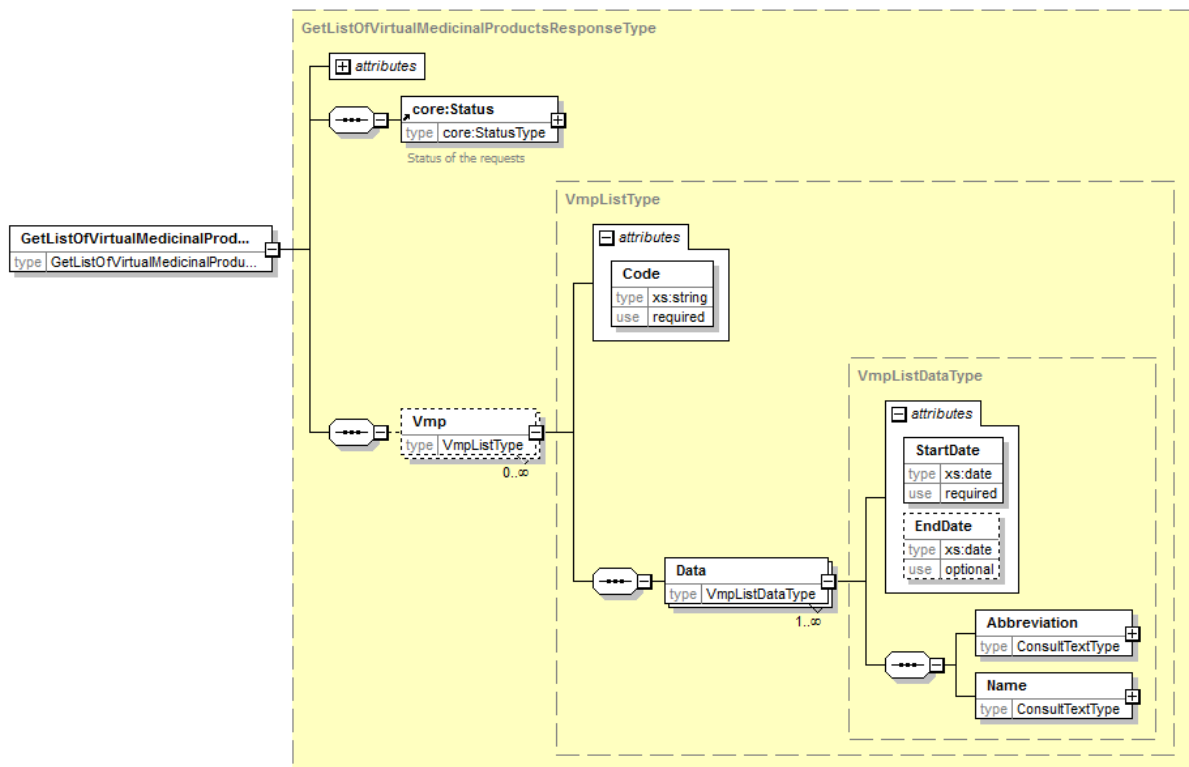

Field Name	Description
------------	-------------

Attributes

See 5.5.25 ConsultCompoundingIngredientType

ConsultCompoundingIngredient...

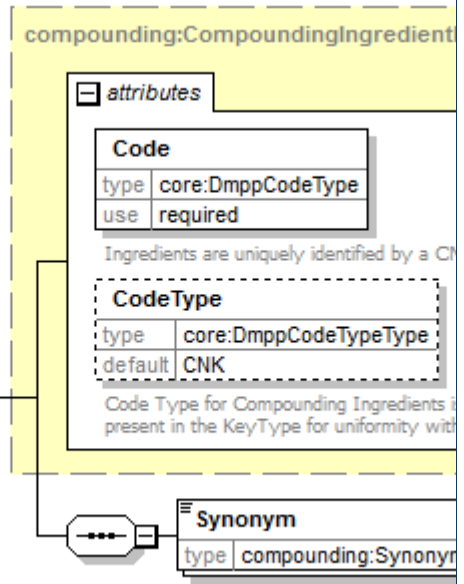

5.3.13 ConsultCompoundingFormulaType

ConsultCompoundingFormulaT...

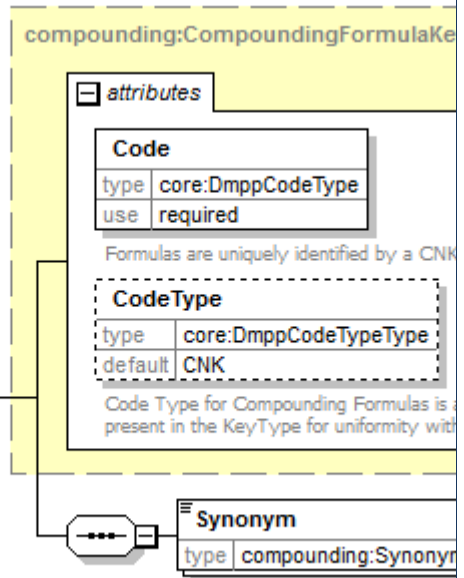

5.3.14 SynonymType

	<div style="border: 1px solid black; padding: 5px;"> <div style="border-bottom: 1px solid black; padding-bottom: 5px;"> attributes </div> <div style="border: 1px dashed black; padding: 5px; margin-bottom: 5px;"> xml:lang <pre> <div> <h3>lang (as an attribute name)</h3> <p> denotes an attribute whose value is a language code for the natural language of the content of any element; its value is inherited. This name is reserved by virtue of its definition in the XML specification.</p> </div> <div> <h4>Notes</h4> <p> Attempting to install the relevant ISO 2- and 3-letter codes as the enumerated possible values is probably never going to be a realistic possibility. </p> <p> See BCP 47 at http://www.rfc-editor.org/rfc/bcp/bcp47.bt and the IANA language subtag registry at http://www.iana.org/assignments/language-subtag-registry for further information. </p> <p> The union allows for the 'un-declaration' of xml:lang with the empty string. </p> </div> </pre> </div> <div style="border: 1px dashed black; padding: 5px; margin-bottom: 5px;"> Rank </div> <div style="border: 1px dashed black; padding: 5px;"> type xs:int <p>Optional rank of the synonym. Synonyms may be ordered by importance or frequency of use.</p> </div> </div> <div style="border: 1px solid black; padding: 5px; margin-top: 10px; width: fit-content;"> SynonymType </div> <table border="1" style="width: 100%; border-collapse: collapse; margin-top: 10px;"> <thead> <tr style="background-color: #e1eef6;"> <th style="text-align: left;">Field name</th> <th style="text-align: left;">Description</th> </tr> </thead> <tbody> <tr> <td>xml:lang</td> <td>The language of this synonym</td> </tr> <tr> <td>Rank</td> <td>Optional rank of the synonym. Synonyms may be ordered by importance or frequency of use. A smaller number is a higher rank.</td> </tr> </tbody> </table> <p>ListConsultationResponseType</p>	Field name	Description	xml:lang	The language of this synonym	Rank	Optional rank of the synonym. Synonyms may be ordered by importance or frequency of use. A smaller number is a higher rank.
Field name	Description						
xml:lang	The language of this synonym						
Rank	Optional rank of the synonym. Synonyms may be ordered by importance or frequency of use. A smaller number is a higher rank.						
Vmp/Code	The unique identifier attributed by BCPI to a Virtual Product						
Vmp/Data	A VMP may have had different validity periods with different data over time. All data blocks are returned						
Vmp/Data/@StartDate	The start date of the current data block/validity period						
Vmp/Data/@EndDate	The end date. If null, then the current block is valid indefinitely						
Vmp/Data/Abbreviation	Common abbreviation of the product, translated in at least Dutch and French						
Vmp/Data/Name	Official name of the product, translated in at least Dutch and French						

5.3.15 GetListOfVmpGroups

Since DICS v4

5.3.15.1 Input arguments

See 5.3.12 GetListOfVirtualMedicinalProducts

5.3.15.2 Output arguments

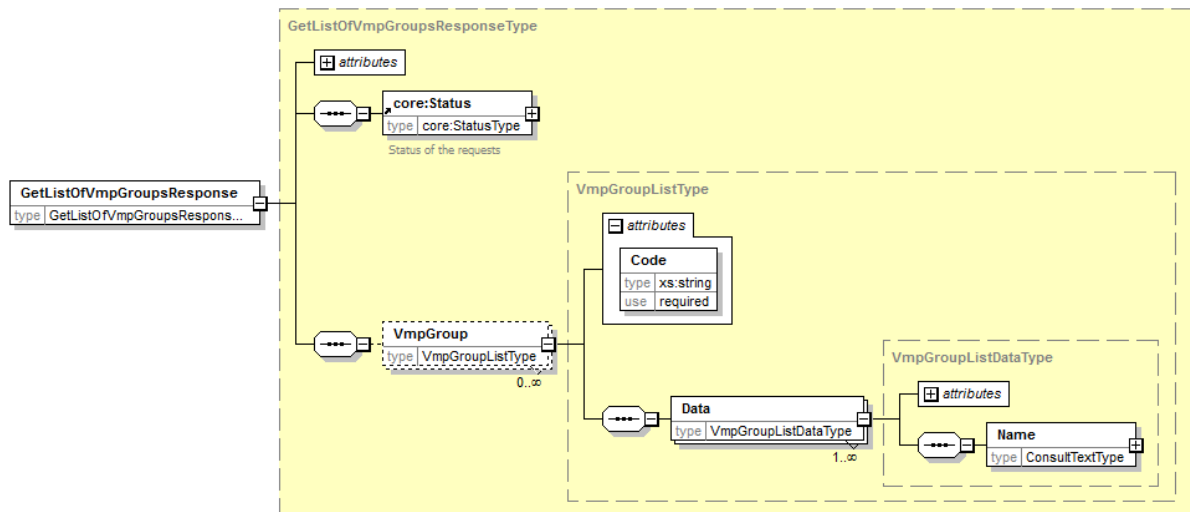

Field name	Description
VmpGroup/Code	The unique identifier attributed by BCPI to a VmpGroup / Generic Prescription Group
VmpGroup/Data/Name	The name attributed to the VmpGroup, translated in at least Dutch and French.
Other fields	See above

5.3.16 ConsultCompoundingFormulaType

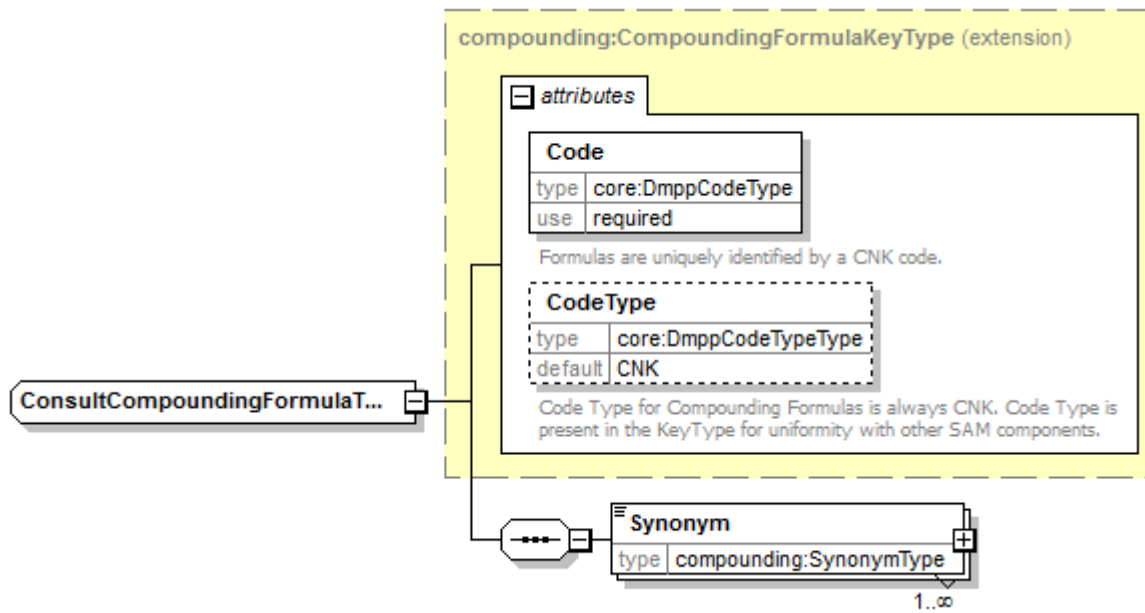

5.3.17 SynonymType

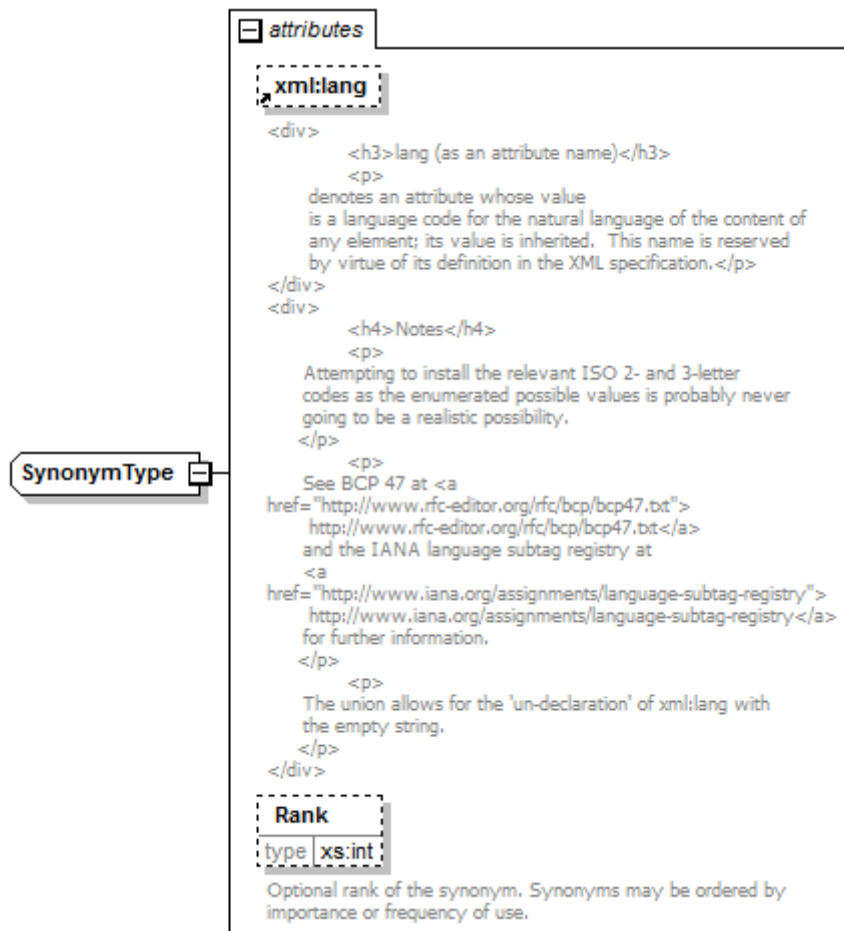

Field name	Description
xml:lang	The language of this synonym
Rank	Optional rank of the synonym. Synonyms may be ordered by importance or frequency of use. A smaller number is a higher rank.

5.3.18 GetListOfActualMedicinalProducts

Since DICS v4

5.3.18.1 Input arguments

See 5.3.12 GetListOfVirtualMedicinalProducts

5.3.18.2 Output arguments

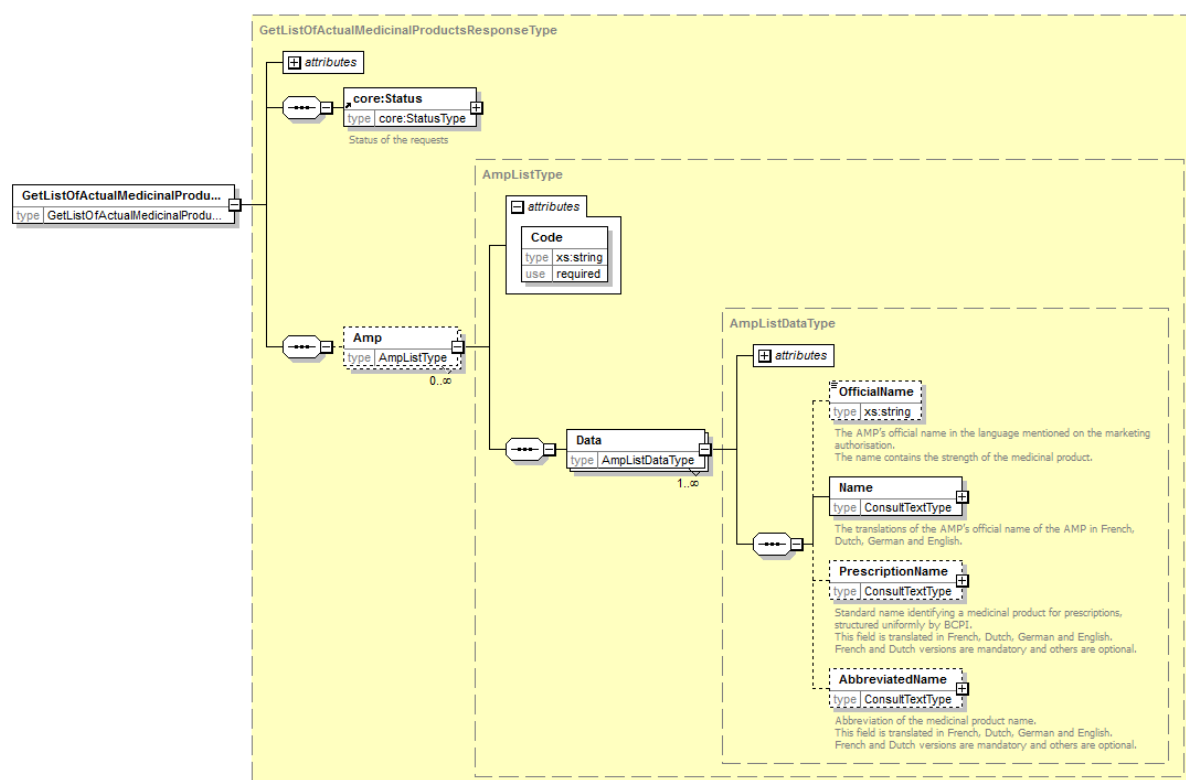

Field name	Description
Amp/Code	Unique identifier created by FAMHP composed of a prefix 'SAM', 6 digits and 2 digits separated by a hyphen.
Amp/Data/OfficialName	The AMP's official name in the language mentioned on the marketing authorisation. The name contains the strength of the medicinal product.
Amp/Data/Name	The translations of the AMP's official name of the AMP in French, Dutch, German and English.

Amp/Data/PrescriptionName	Standard name identifying a medicinal product for prescriptions, structured uniformly by BCPI. This field is translated in French, Dutch, German and English. French and Dutch versions are mandatory and others are optional.
Amp/Data/AbbreviatedName	Abbreviation of the medicinal product name. This field is translated in French, Dutch, German and English. French and Dutch versions are mandatory and others are optional.

5.3.19 GetListOfActualMedicinalProductPackages

Since DICS v4

5.3.19.1 Input arguments

See 5.3.12 GetListOfVirtualMedicinalProducts

5.3.19.2 Output arguments

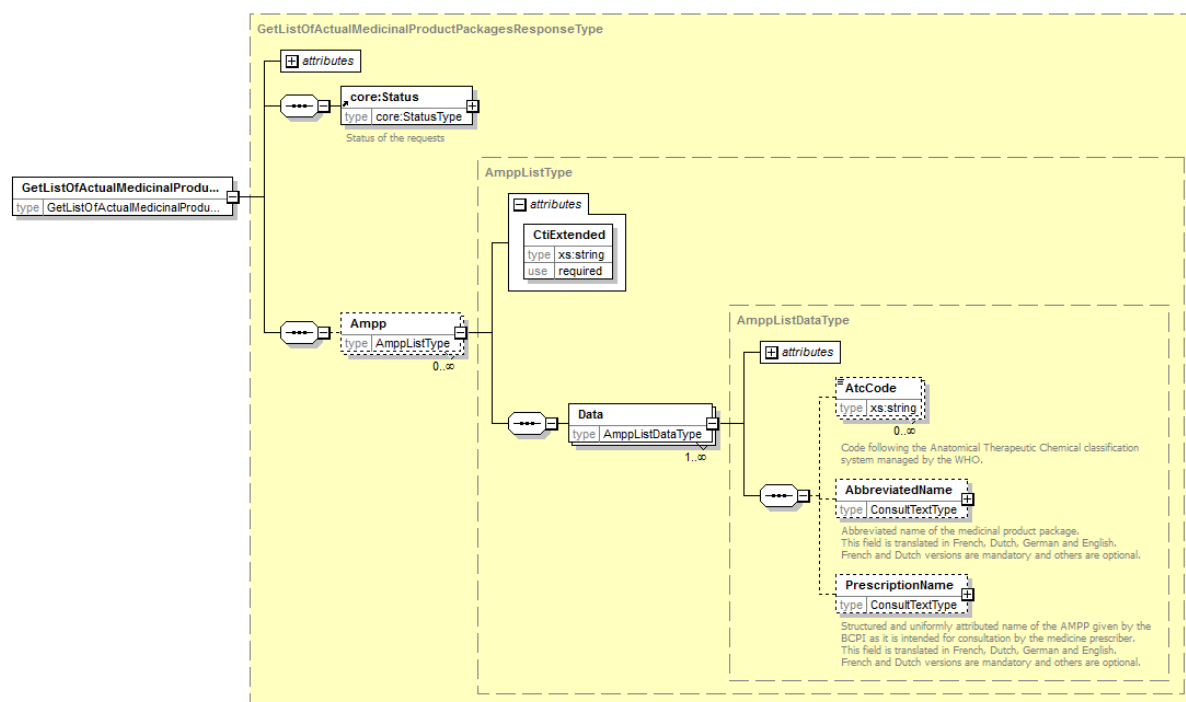

Field name	Description
Amp/CtiExtended	Unique identifier for a Product Package attributed by the FAMHP.
Amp/Data/AtcCode	Code following the Anatomical Therapeutic Chemical classification system managed by the WHO.
Amp/Data/AbbreviatedName	Abbreviated name of the medicinal product package. This field is translated in French, Dutch, German and English. French and Dutch versions are mandatory and others are optional.

AmpData/PrescriptionName	<p>Structured and uniformly attributed name of the AMPP given by the BCPI as intended for consultation by the medicine prescriber.</p> <p>This field is translated in French, Dutch, German and English.</p> <p>French and Dutch versions are mandatory and others are optional.</p>
---------------------------------	--

5.3.20 FindAmp

Since DICS v4

Consultation method for retrieving a single package instead of a full Product with possibly a multitude of packages.

Interface provided in DICS but currently unimplemented.

5.3.20.1 Input arguments

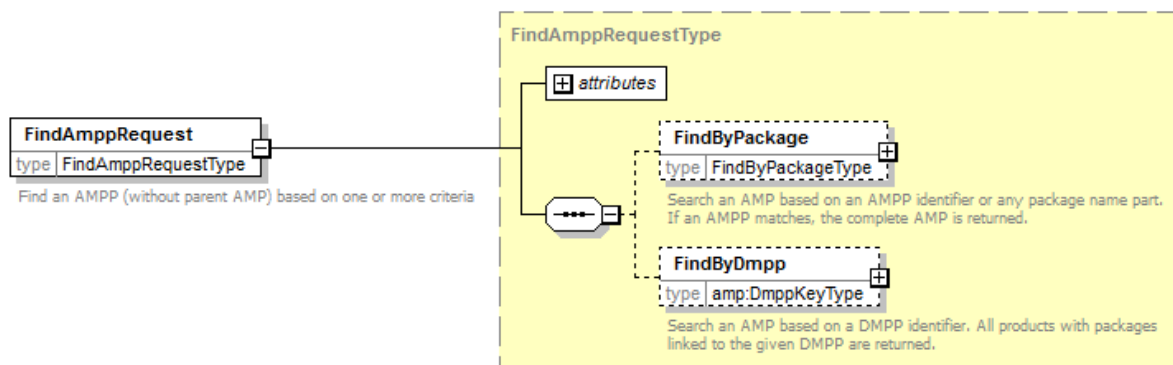

5.3.20.2 Output arguments

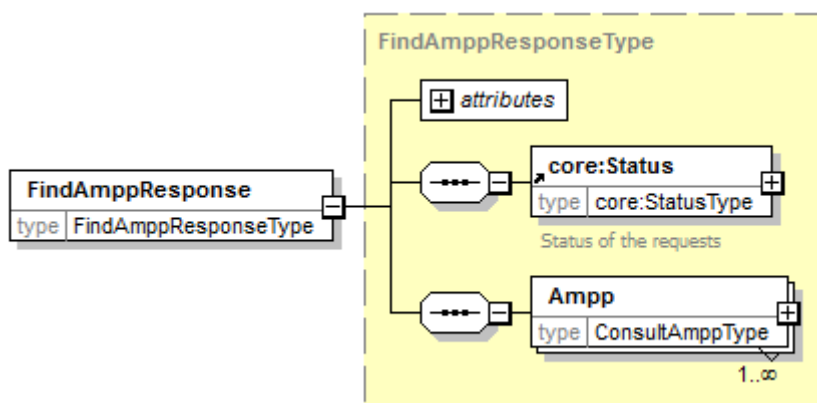

5.3.21 FindNonMedicinalProduct

Since DICS v4

5.3.21.1 Input arguments

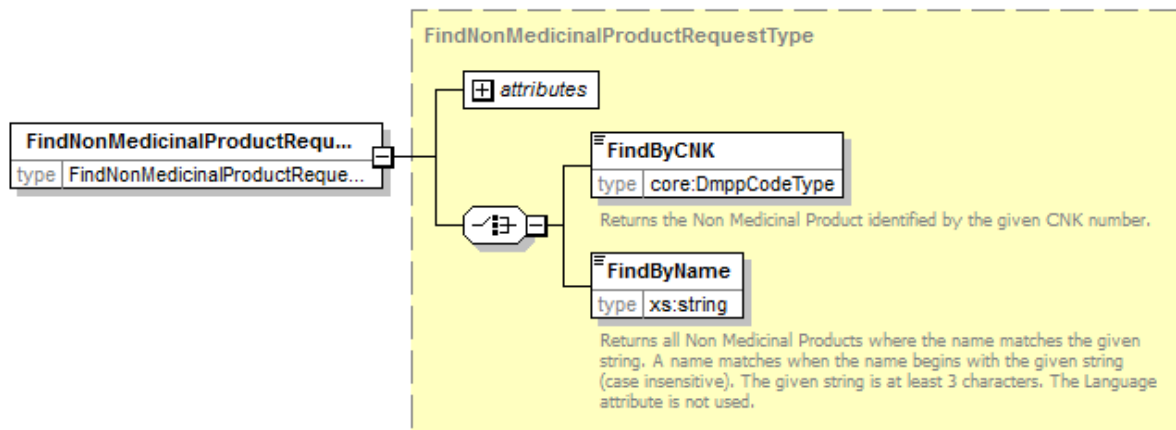

Field name	Description
FindByCNK	Returns the Non Medicinal Product identified by the given CNK number.
FindByName	Returns all Non Medicinal Products where the name matches the given string. A name matches when the name begins with the given string (case insensitive). The given string is at least 3 characters. The Language attribute is not used.

5.3.21.2 Output arguments

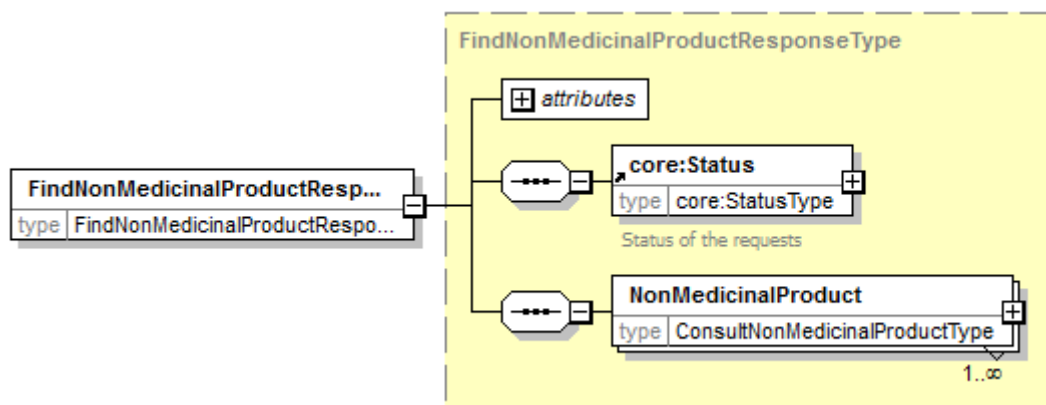

5.4 Request Types

5.4.1 FindByActualProduct

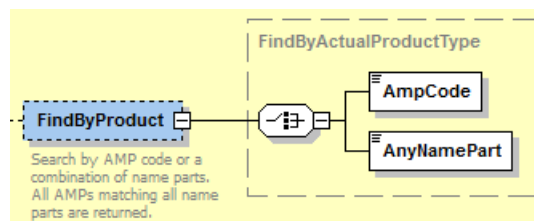

Field name	Descriptions
AmpCode	The AMP Code for the requested product. Formatted as SAM-xxxxxx-xx, with the x's being digits [0-9]
AnyNamePart	Looks for AMPs with Official Name or Localized Name starting with the given string.

5.4.2 FindByPackage

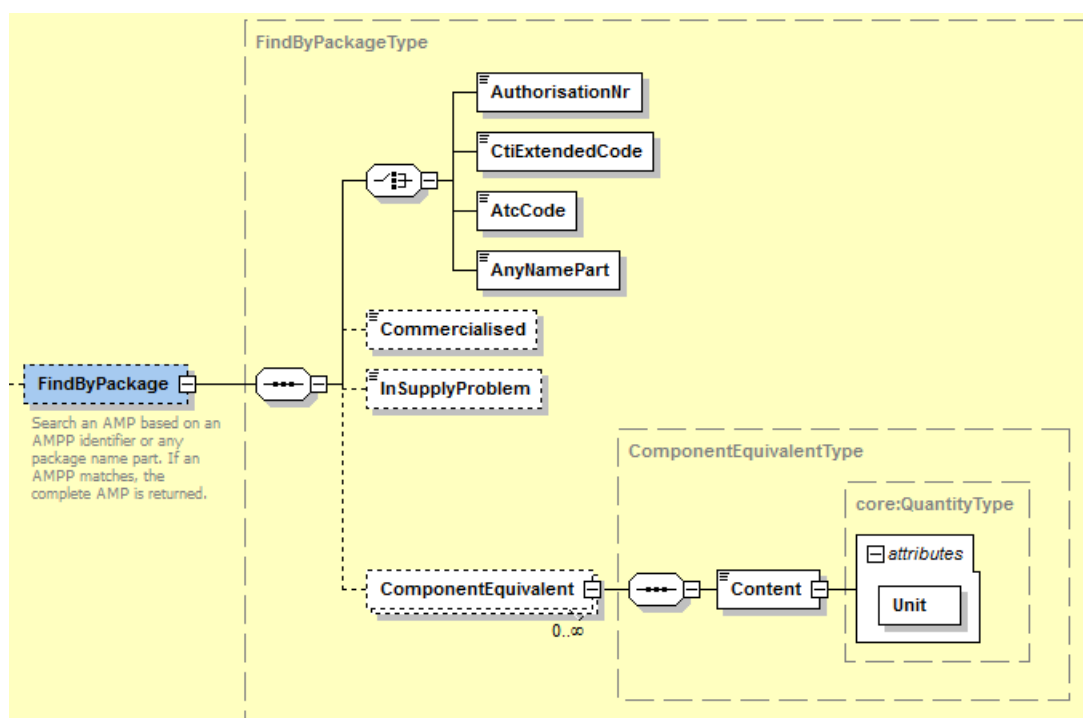

Field name	Descriptions
AuthorisationNr	Authorisation number given by FAMPH or European Commission when authorised to be commercialised on the Belgian market.
CtiExtendedCode	Unique identifier for an Actual Medicinal Product Package
AtcCode	Anatomical Therapeutic Chemical classification system managed by the WHO ⁷ .
AnyNamePart	Search for the string in any name field of the Package.
Commercialised	The package(s) identified by any of the above criteria are Commercialised at the given date. Boolean.
InSupplyProblem	The package(s) identified by any of the above criteria are In Supply Problem at the given date. Boolean.
ComponentEquivalent > Content	Related equivalent content packaging specifications of the AMPP Component. Attribute: Unit (a unit that is available in the reference tables)

⁷ http://www.whocc.no/atc/structure_and_principles/.

5.4.3 FindByDmpp

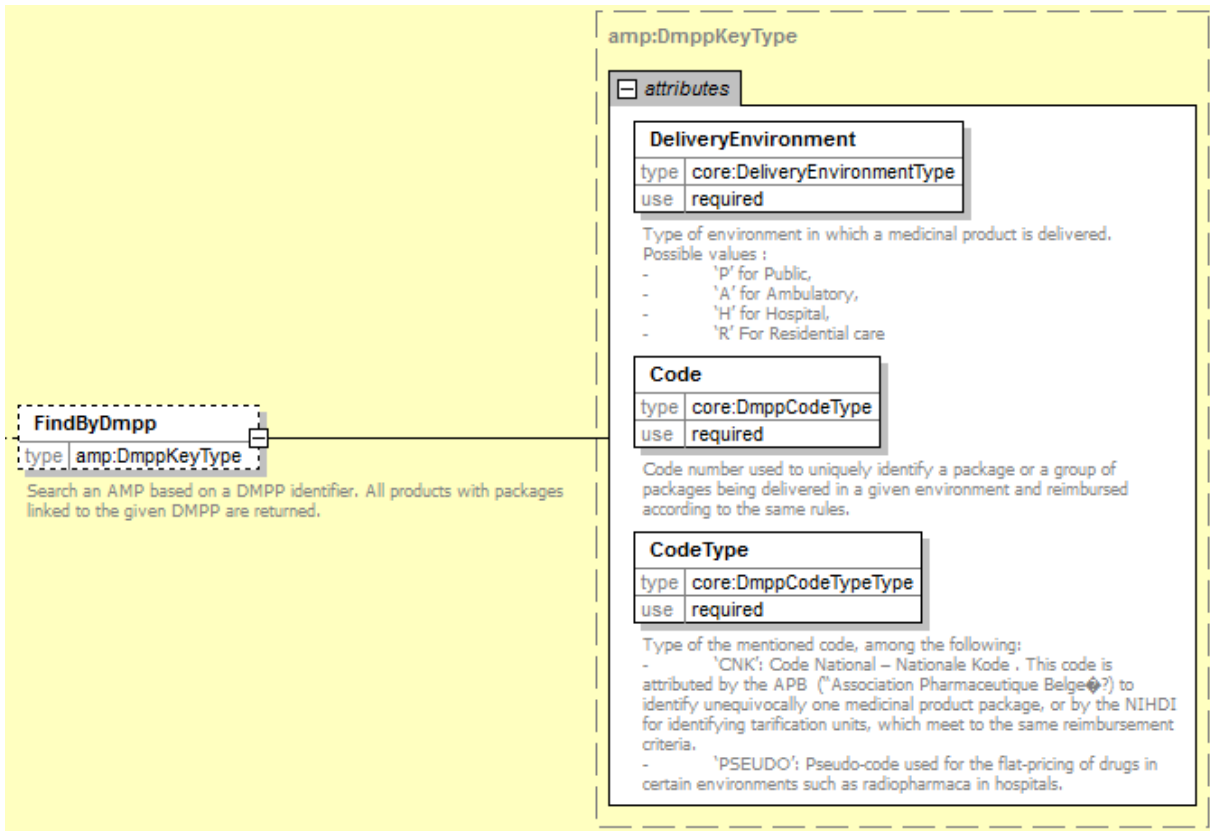

5.4.4 FindByIngredient

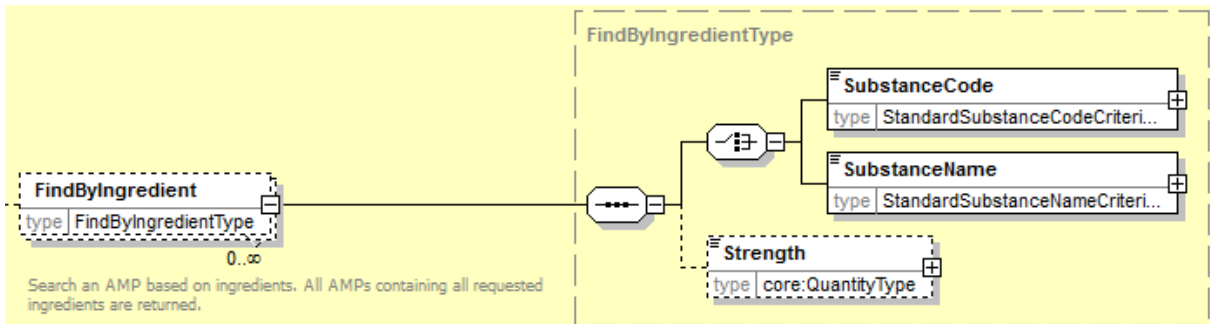

5.4.5 FindByVirtualProduct

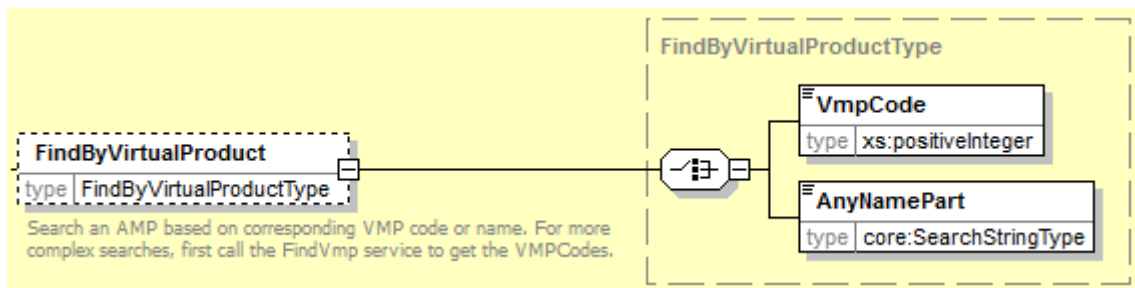

5.4.6 FindByGenericPrescriptionGroup

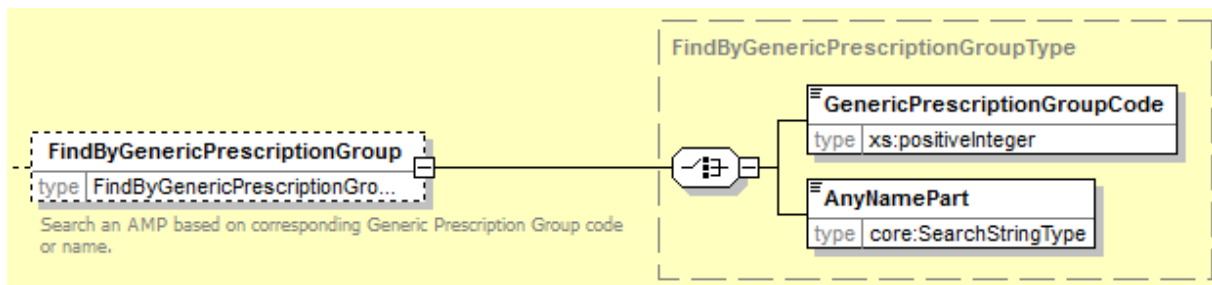

5.4.7 FindByCompany

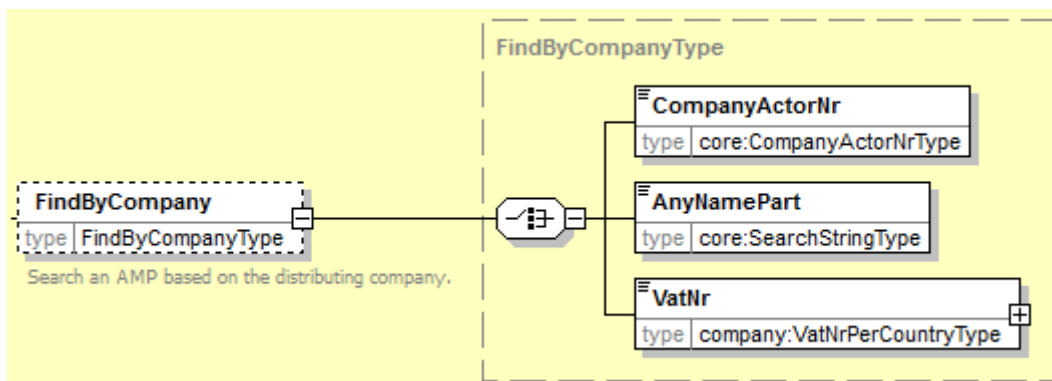

5.4.8 FindByTherapeuticMoiety

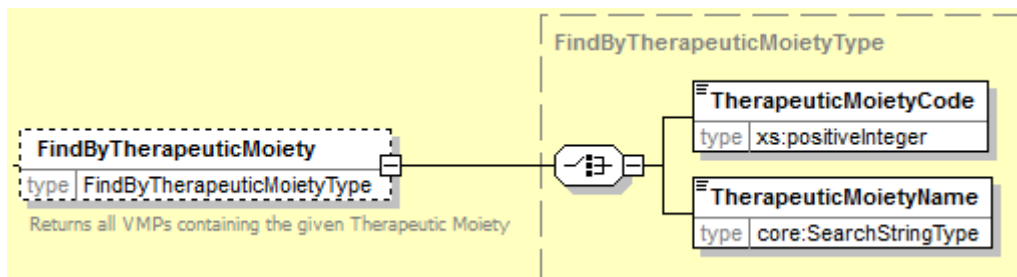

5.4.9 FindByCommentedClassification

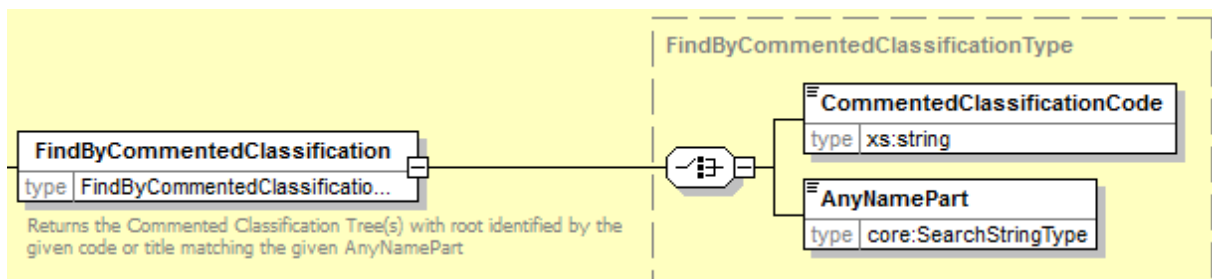

5.4.10 HasActualComponentWith

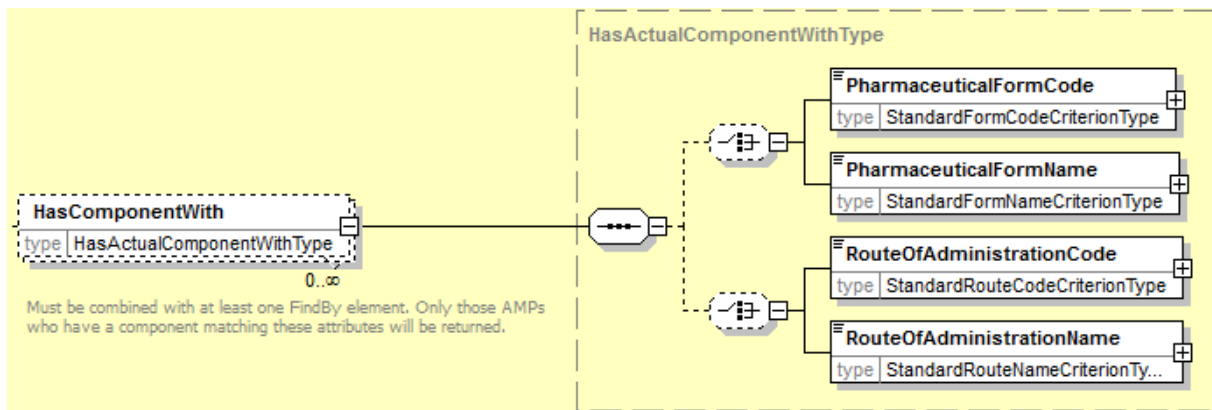

5.4.11 HasVirtualComponentWith

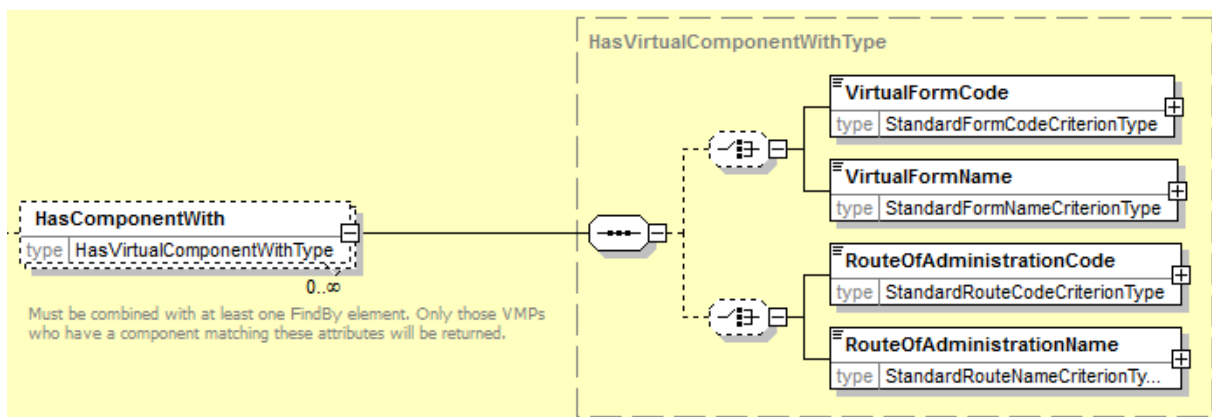

5.4.12 HasWadaClassification

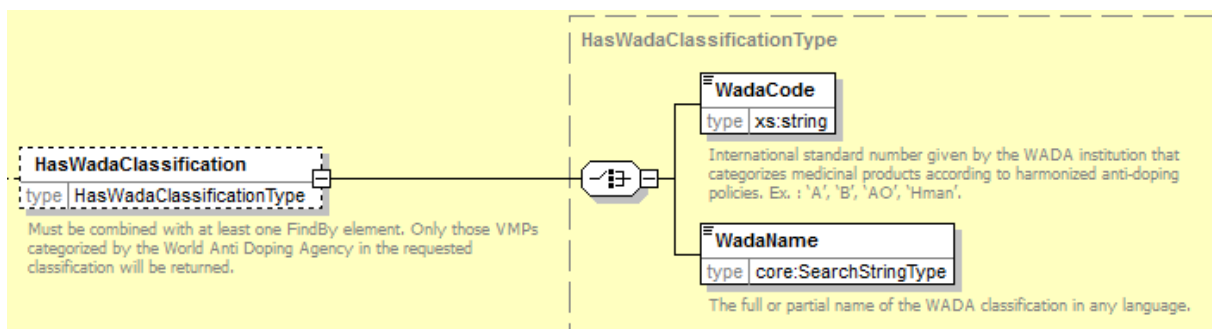

5.4.13 ListConsultationRequestType

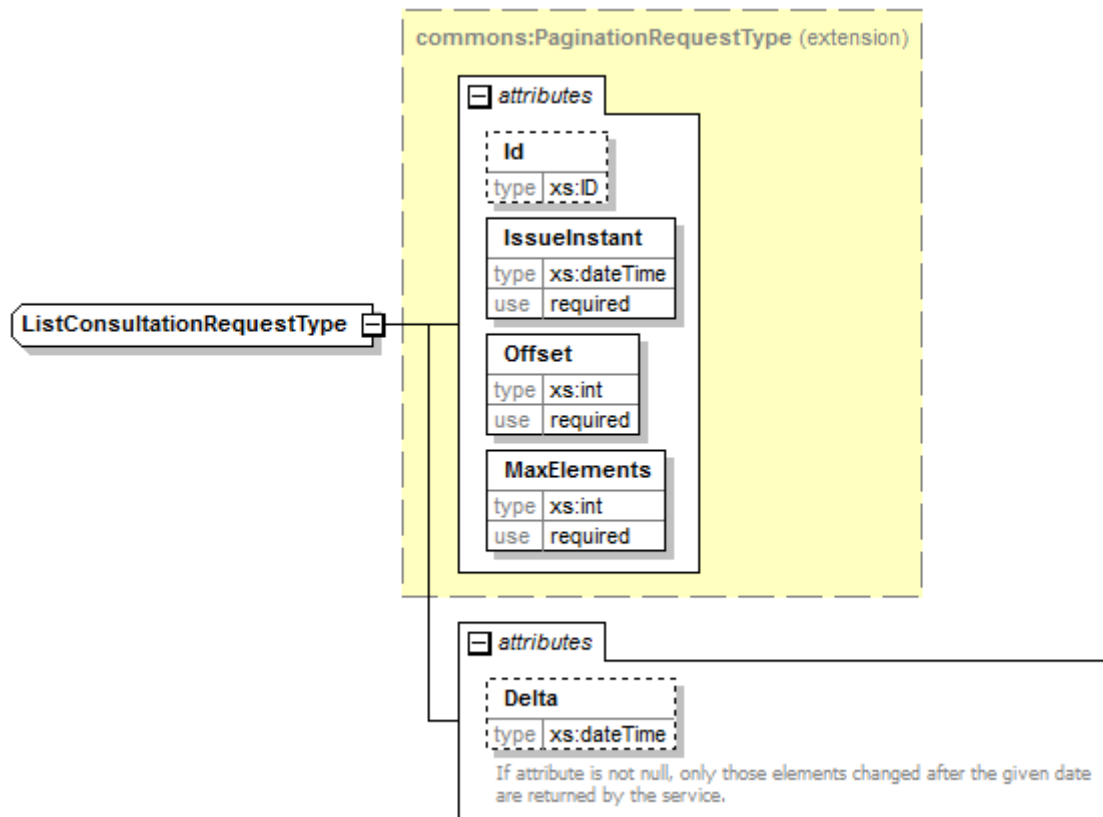

Field name	Description
Id	See 5.2.1 Generic attributes
IssueInstant	See 5.2.1 Generic attributes
Offset	Used for pagination. Returns the number of results defined in MaxElements, starting from the specified Offset. The first result has index 0. Default: 0
MaxElements	Used for pagination. Returns the number of results defined in MaxElements, starting from the specified Offset. The first result has index 0. Default: 100
Delta	If attribute is not null, only those elements changed after the service returns the given date.

5.5 Response Types

5.5.1 ConsultAmpType

ConsultAmpType		
ⓐ Code	string	
ⓐ VmpCode	positiveInteger	
ⓐ	ⓐ StartDate	date
	ⓐ EndDate	date
ⓔ Status		
ⓔ Name	ConsultTextType	
ⓔ BlackTriangle	boolean	
ⓔ MedicineType		
ⓔ OfficialName	[0..1] string	
ⓔ AbbreviatedName	[0..1] ConsultTextType	
ⓔ ProprietarySuffix	[0..1] ConsultTextType	
ⓔ PrescriptionName	[0..1] ConsultTextType	
ⓔ CompanyActorNr		
ⓔ AmpComponent	[1..*] ConsultAmpComponentType	
ⓔ Amp	[0..*] ConsultAmpType	

5.5.2 ConsultAmpComponentType

ConsultAmpComponentType		
ⓐ SequenceNr	positiveInteger	
ⓐ VmpComponentCode	positiveInteger	
ⓐ	ⓐ StartDate	date
	ⓐ EndDate	date
ⓔ Dividable	[0..1]	
ⓔ Scored	[0..1]	
ⓔ Crushable	[0..1]	
ⓔ ContainsAlcohol	[0..1]	
ⓔ SugarFree	[0..1] boolean	
ⓔ ModifiedReleaseType	[0..1]	
ⓔ SpecificDrugDevice	[0..1]	
ⓔ Dimensions	[0..1] string	
ⓔ Name	[0..1] ConsultTextType	
ⓔ Note	[0..1] ConsultTextType	
ⓔ PharmaceuticalForm	[1..*] PharmaceuticalFormWithStandardsType	
ⓔ RouteOfAdministration	[1..*] RouteOfAdministrationWithStandardsType	
ⓔ RealActualIngredient	[1..*] ConsultRealActualIngredientType	

5.5.3 ConsultRealActualIngredientType

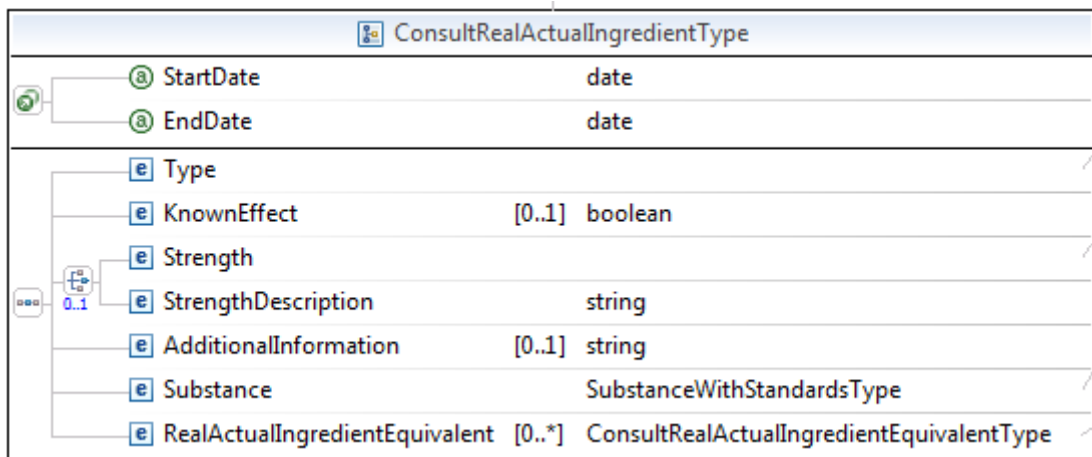

5.5.4 ConsultRealActualIngredientEquivalentType

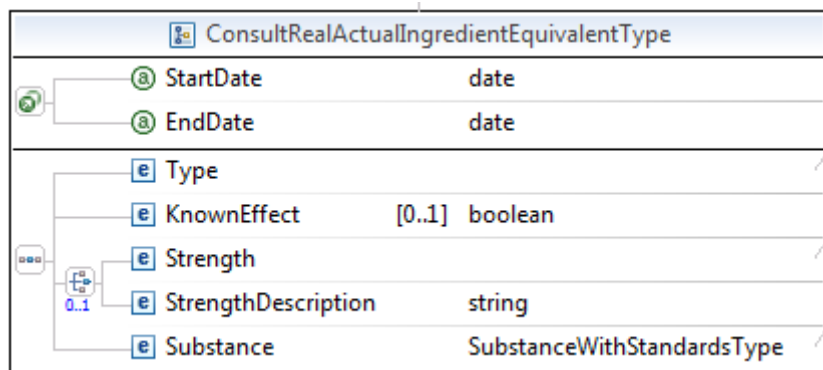

5.5.5 ConsultAmpType

ConsultAmpType		
ⓐ	CtiExtended	
ⓐ	StartDate	date
ⓐ	EndDate	date
e	Orphan	boolean
e	LeafletLink	[0..1] ConsultTextType
e	Spclink	[0..1] ConsultTextType
e	RmaPatientLink	[0..1] ConsultTextType
e	RmaProfessionalLink	[0..1] ConsultTextType
e	ParallelCircuit	[0..1]
e	ParallelDistributor	[0..1] string
e	PackMultiplier	[0..1] positiveInteger
e	PackAmount	[0..1]
e	PackDisplayValue	[0..1] string
e	AuthorisationNr	string
e	SingleUse	[0..1] boolean
e	SpeciallyRegulated	[0..1]
e	AbbreviatedName	[0..1] ConsultTextType
e	PrescriptionName	[0..1] ConsultTextType
e	Note	[0..1] ConsultTextType
e	PosologyNote	[0..1] ConsultTextType
e	CrmLink	[0..1] ConsultTextType
e	ExFactoryPrice	[0..1] decimal
e	ReimbursementCode	[0..1]
e	Atc	[0..*] AtcClassificationType
e	DeliveryModus	DeliveryModusType
e	DeliveryModusSpecification	[0..1] DeliveryModusSpecificationType
e	NoGenericPrescriptionReason	[0..*] NoGenericPrescriptionReasonType
e	DistributorCompanyActorNr	[0..1]
e	AmpComponent	[1..*] ConsultAmpComponentType
e	Commercialization	[0..1] ConsultCommercializationType
e	SupplyProblem	[0..1] ConsultSupplyProblemType
e	DerogationImport	[0..*] ConsultDerogationImportType
e	Dmpp	[0..*] ConsultDmppType

5.5.6 ConsultAmpComponentType

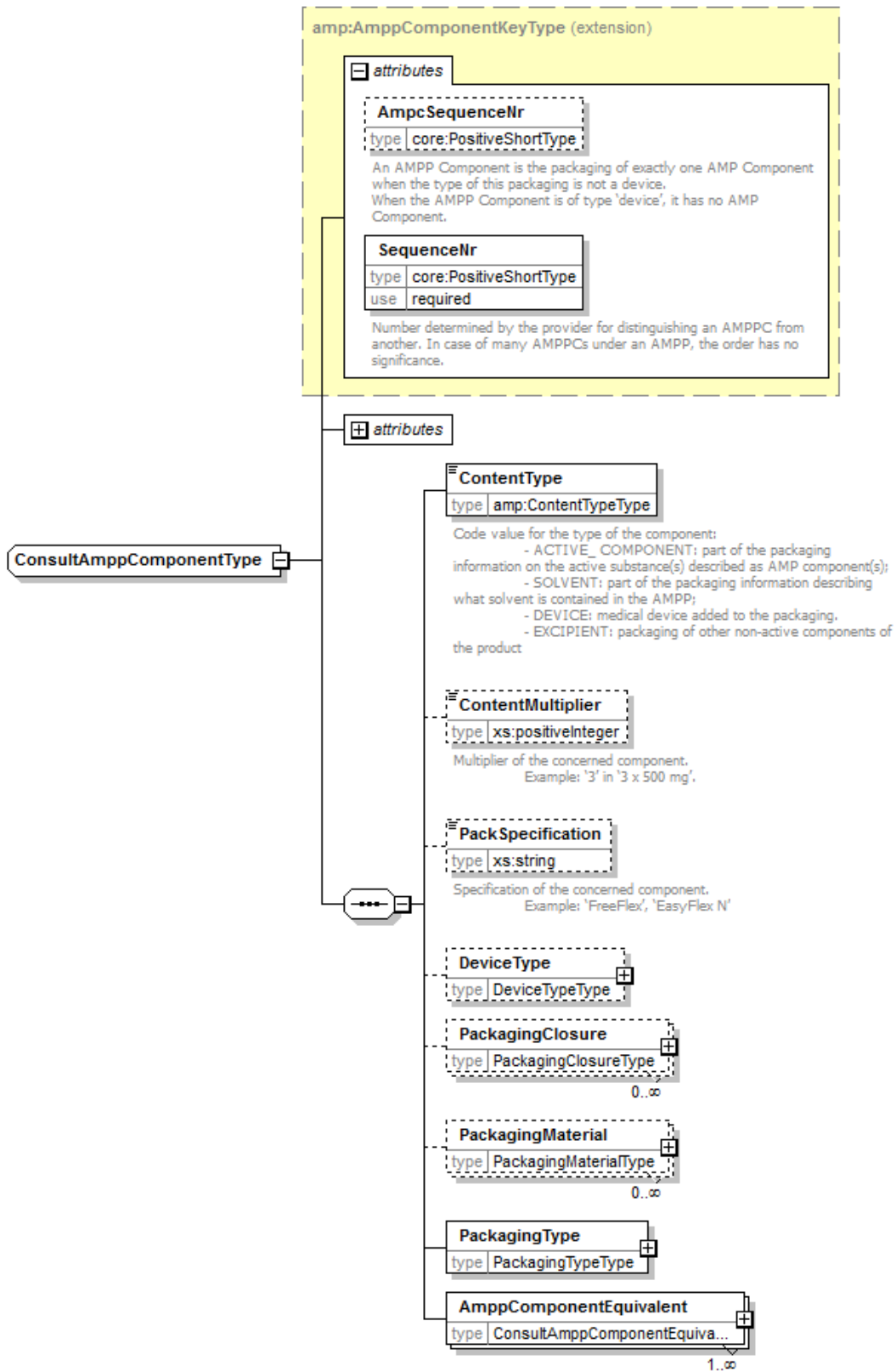

5.5.7 ConsultAmpComponentEquivalentType

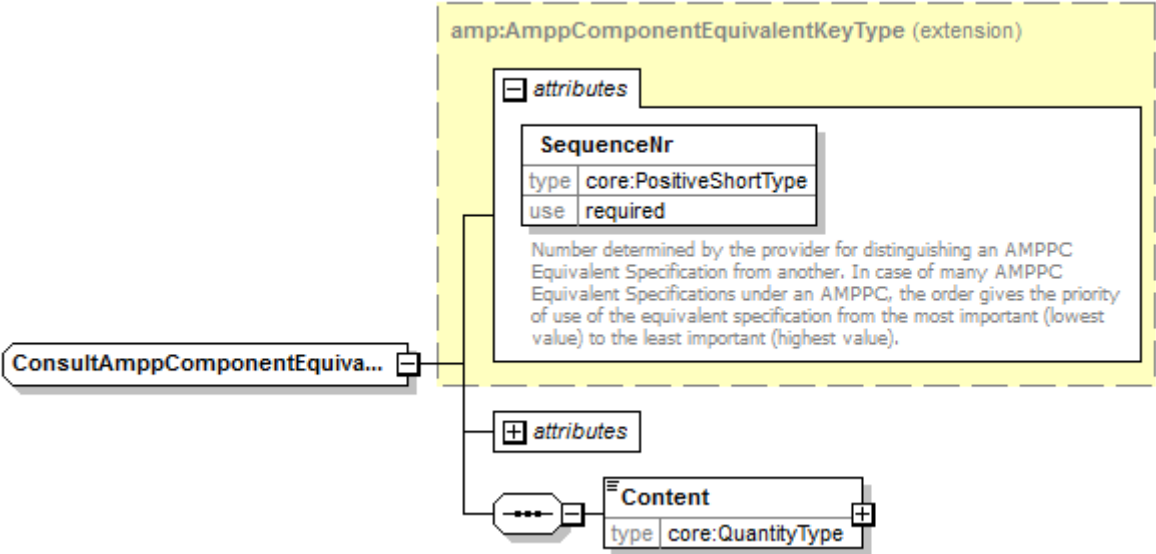

5.5.8 ConsultSupplyProblemType

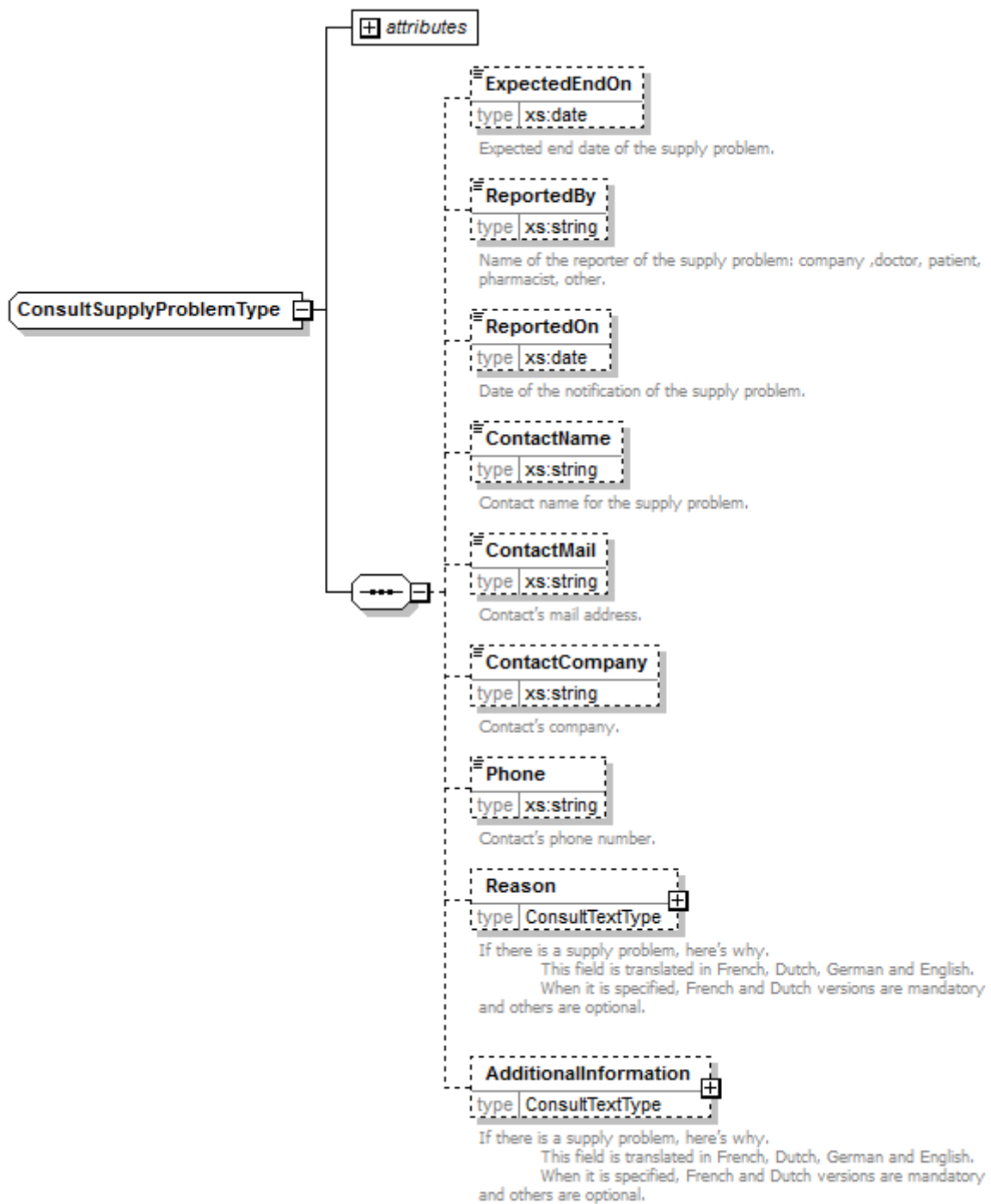

5.5.9 ConsultDerogationImportType

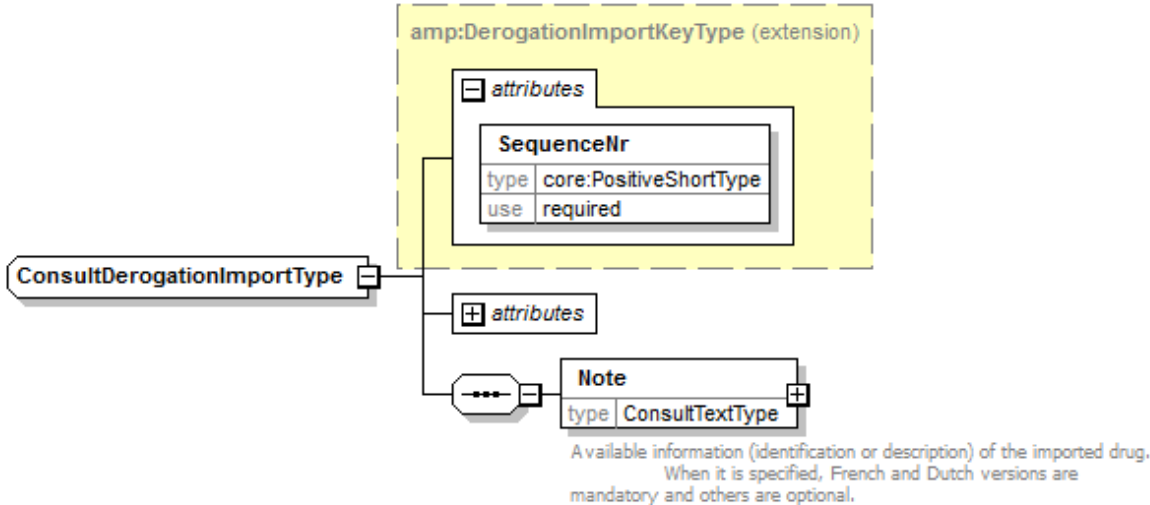

5.5.10 ConsultDmppType

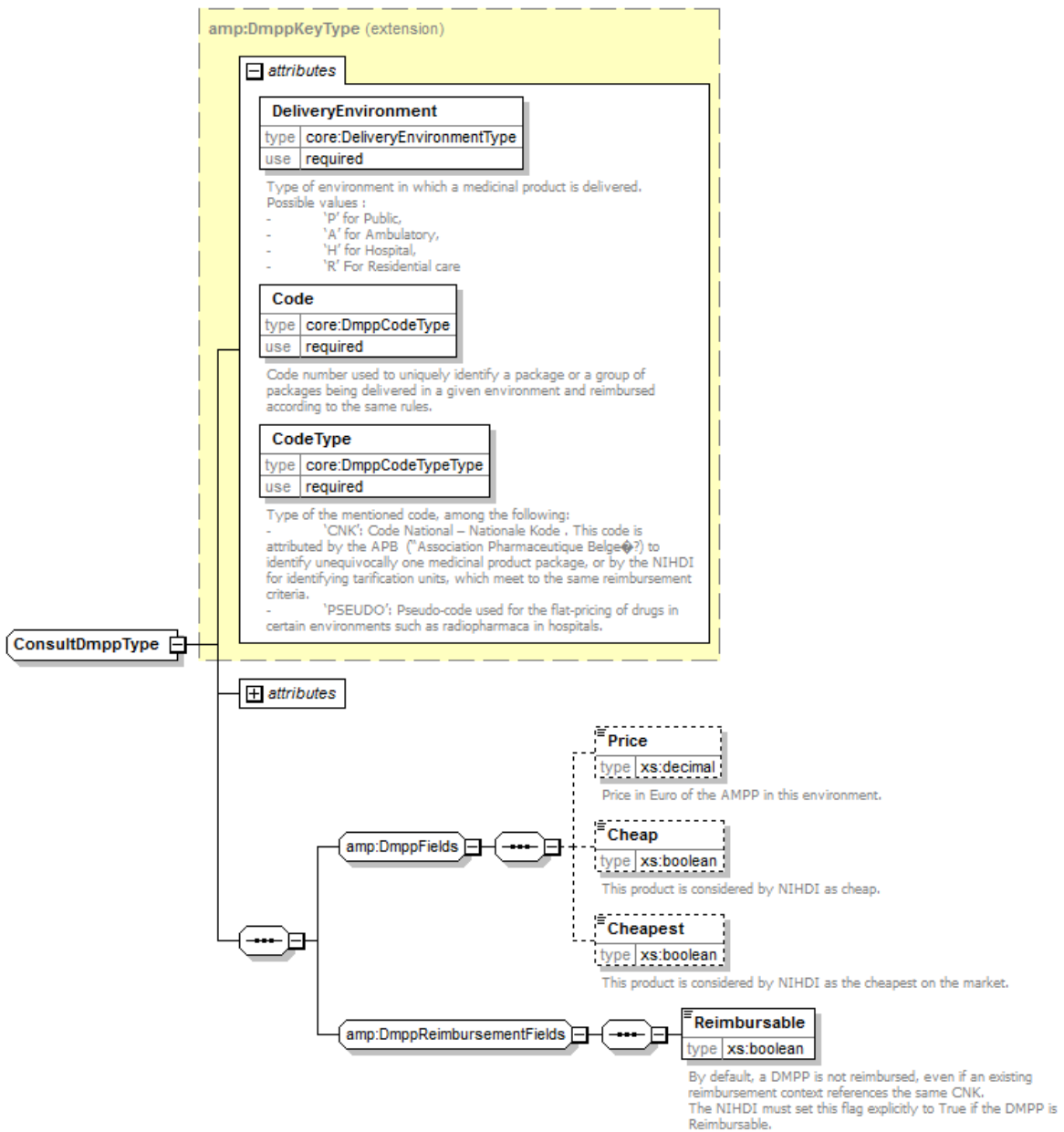

5.5.11 ConsultVmpType

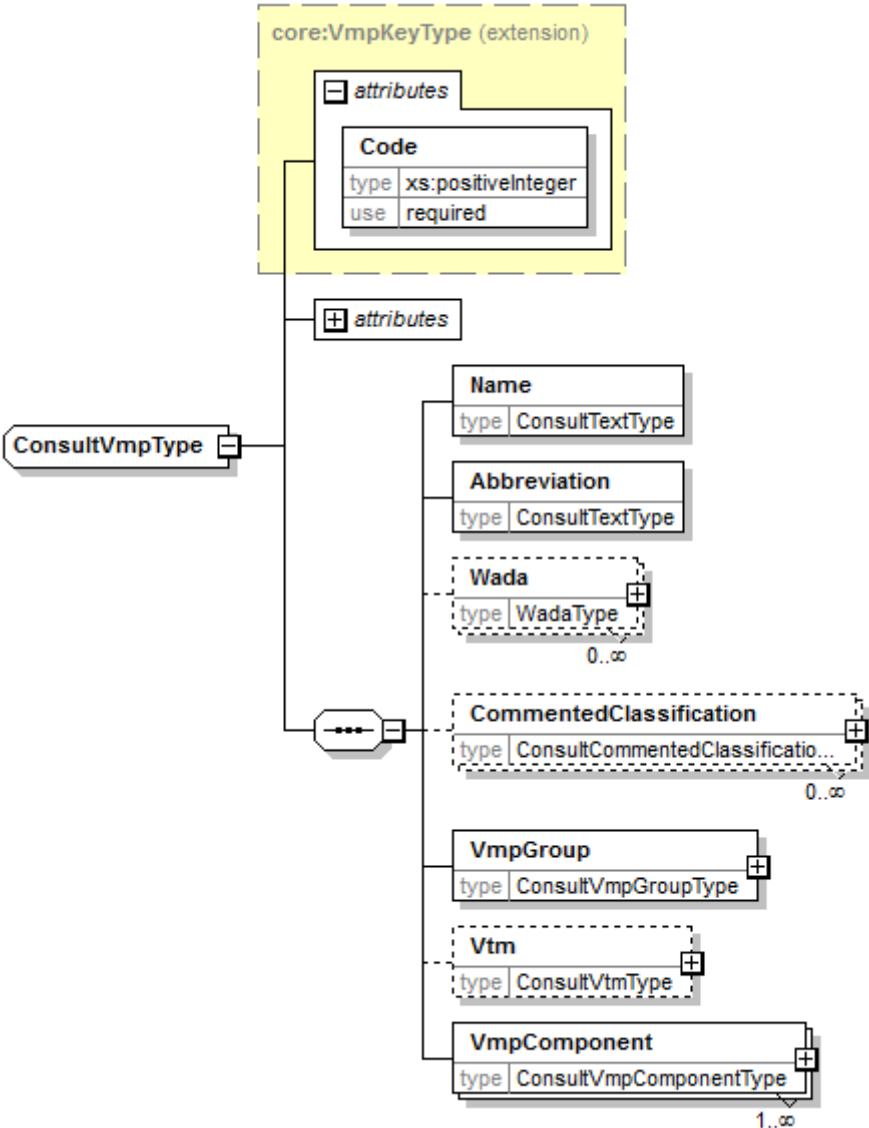

5.5.12 ConsultCommentedClassificationType

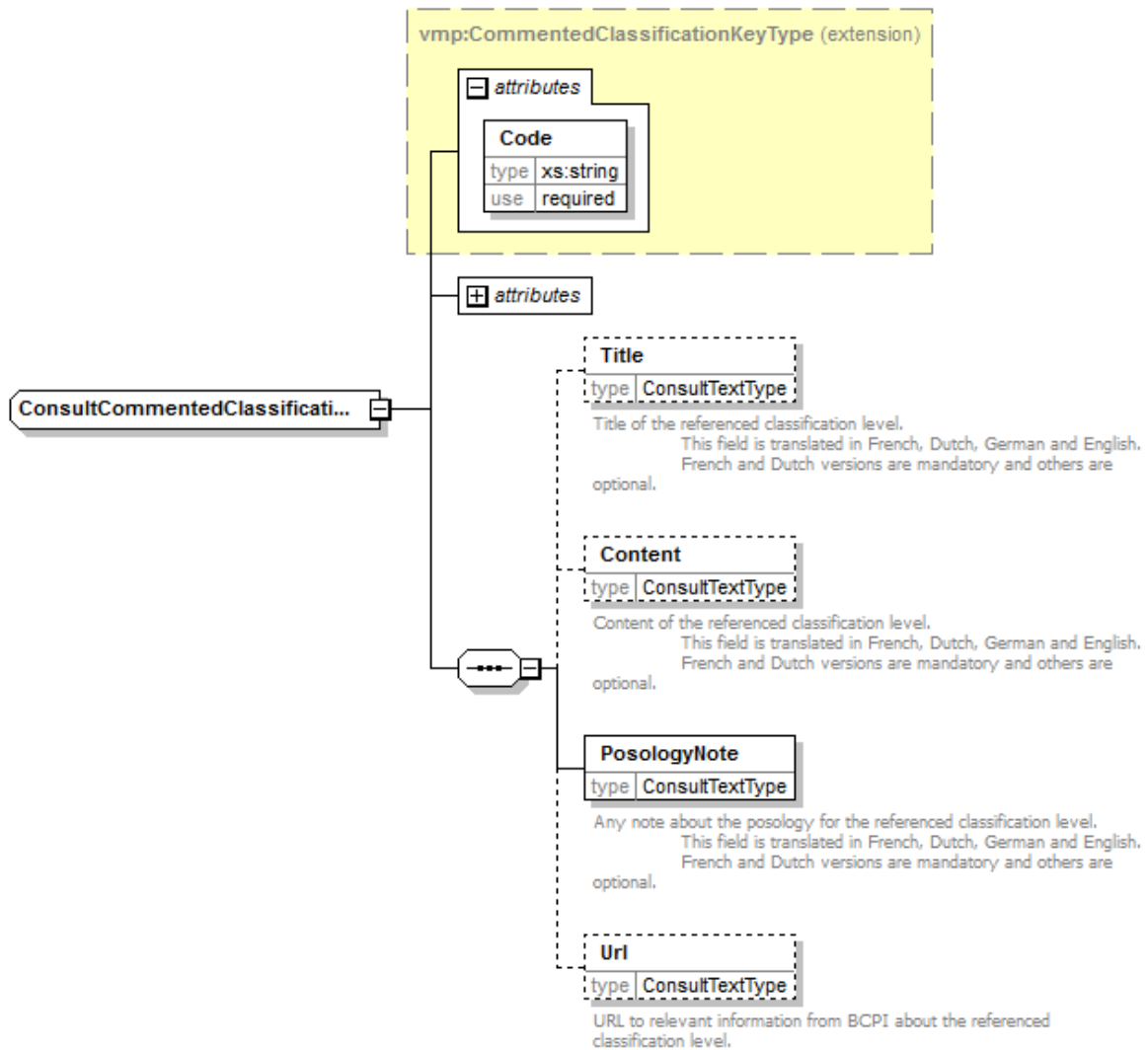

5.5.13 ConsultVmpGroupType

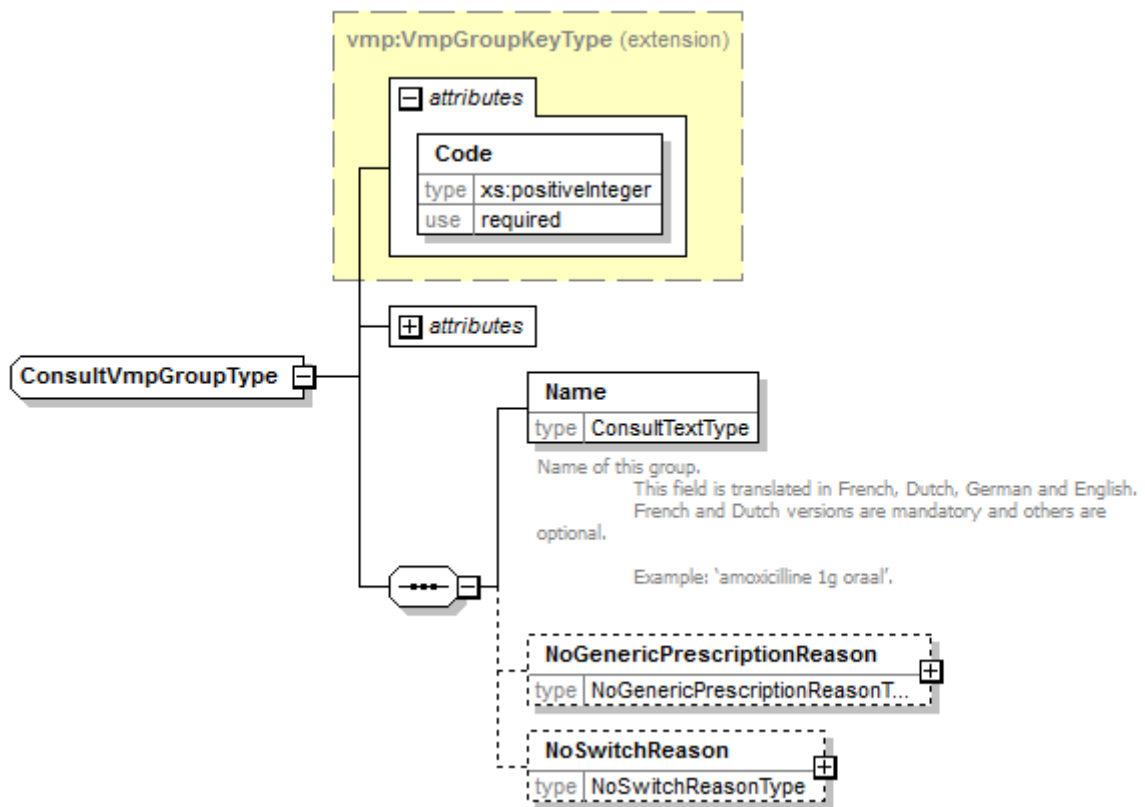

5.5.14 ConsultVtmType

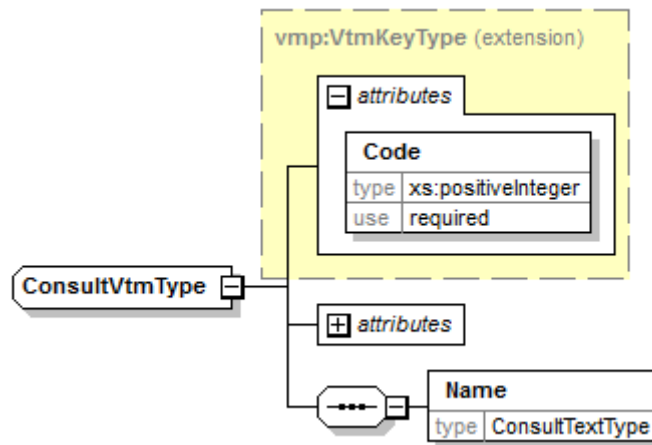

5.5.15 ConsultVmpComponentType

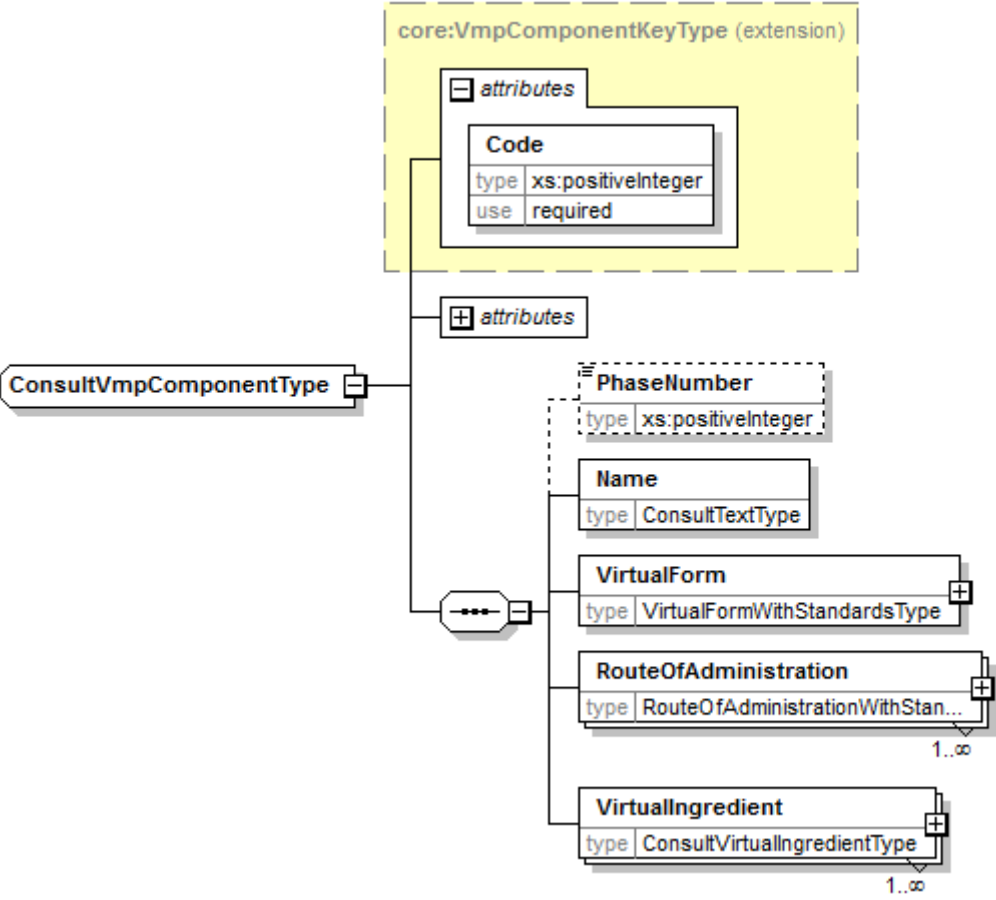

5.5.16 ConsultVirtualIngredientType

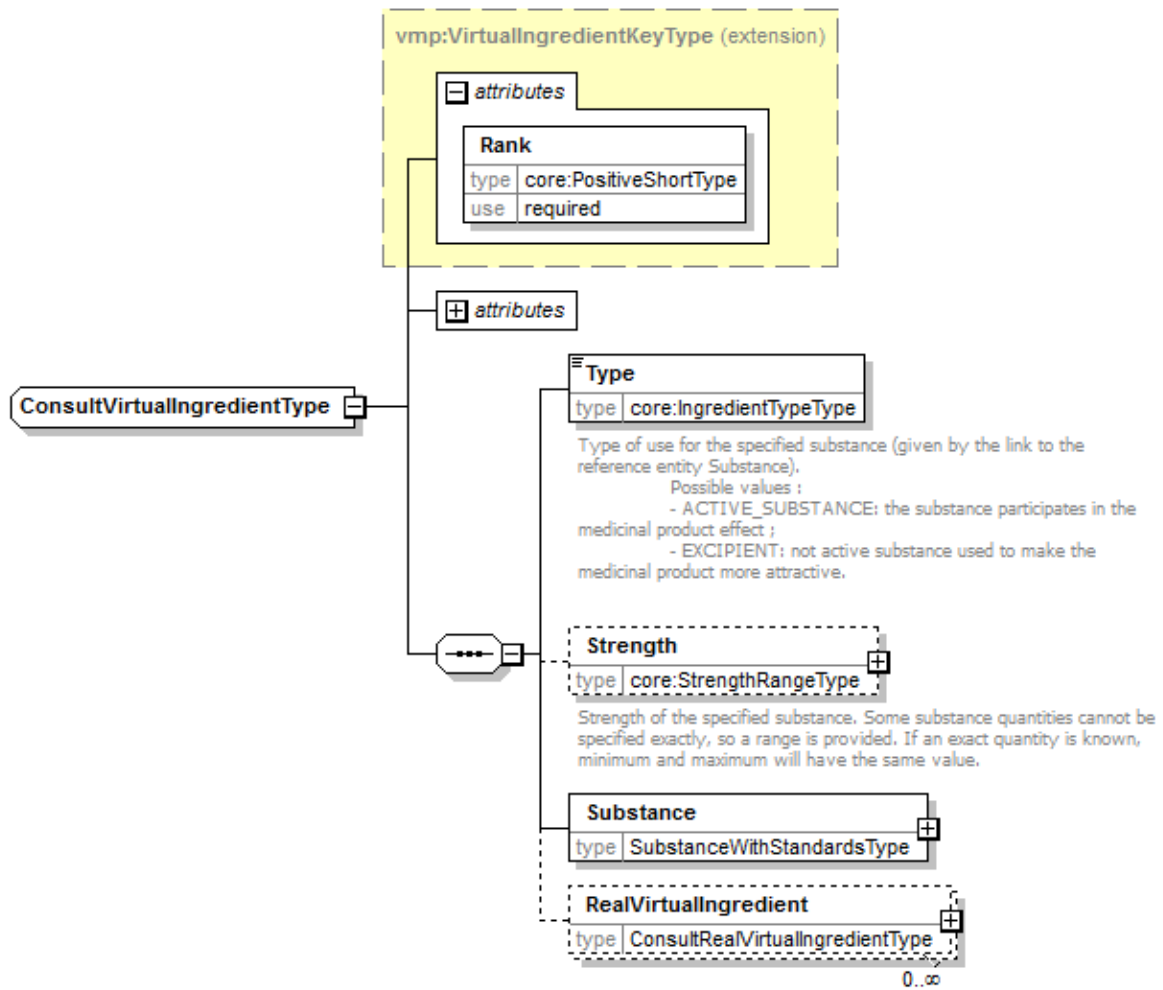

5.5.17 ConsultCompanyType

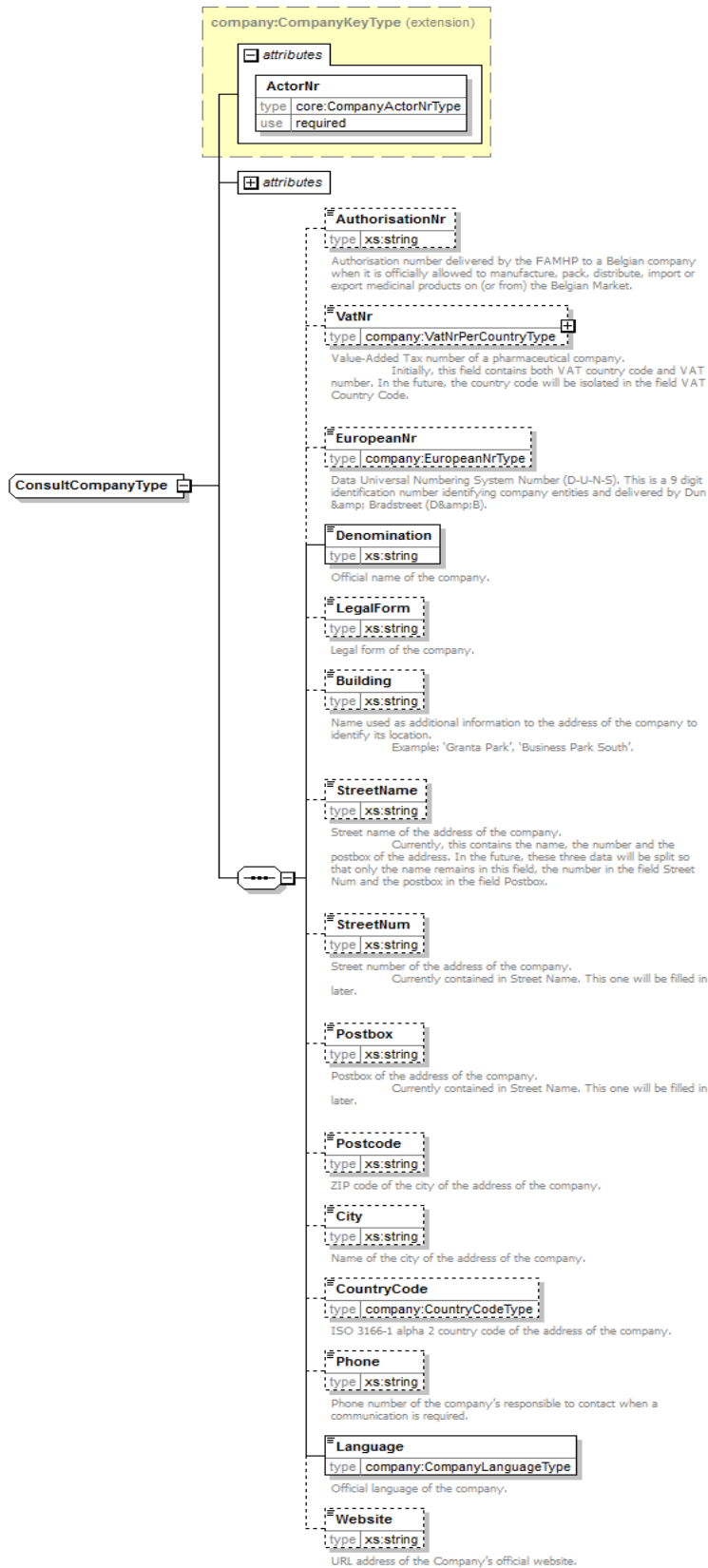

5.5.18 ConsultLegalBasisType

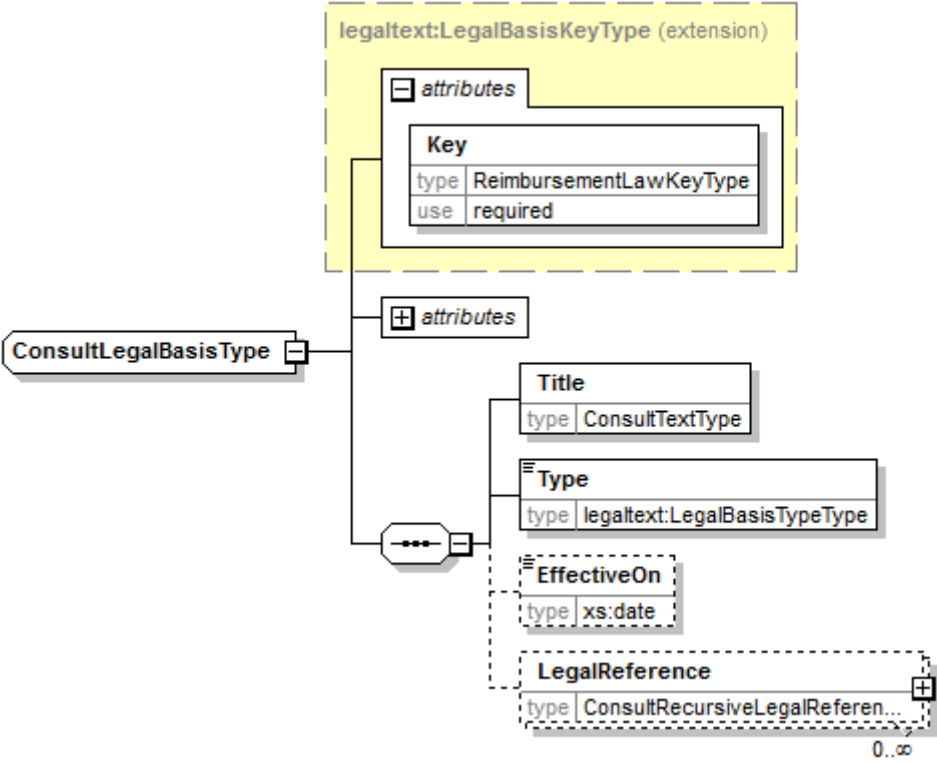

5.5.19 ConsultRecursiveLegalReferenceType

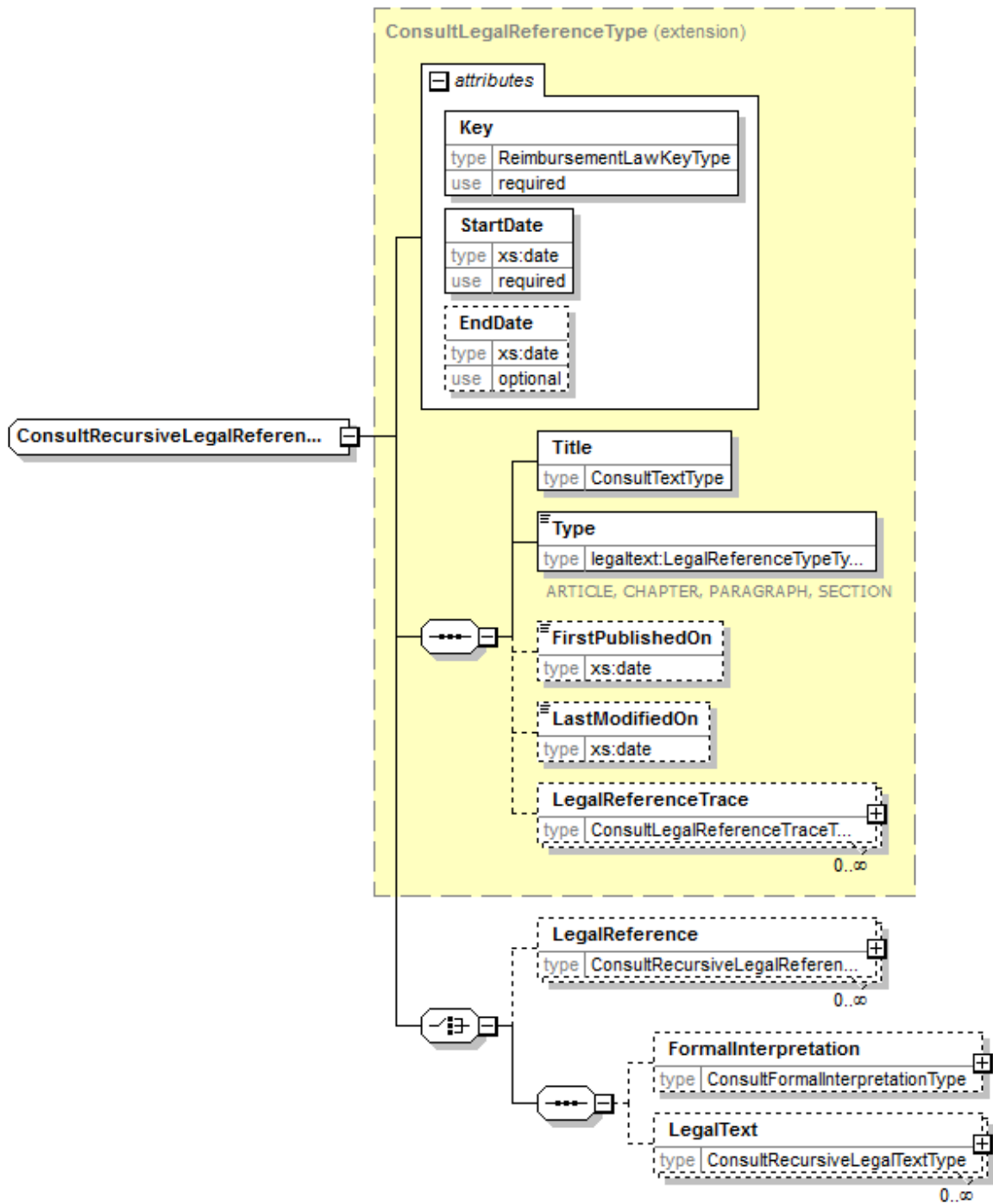

5.5.20 ConsultRecursiveLegalTextType

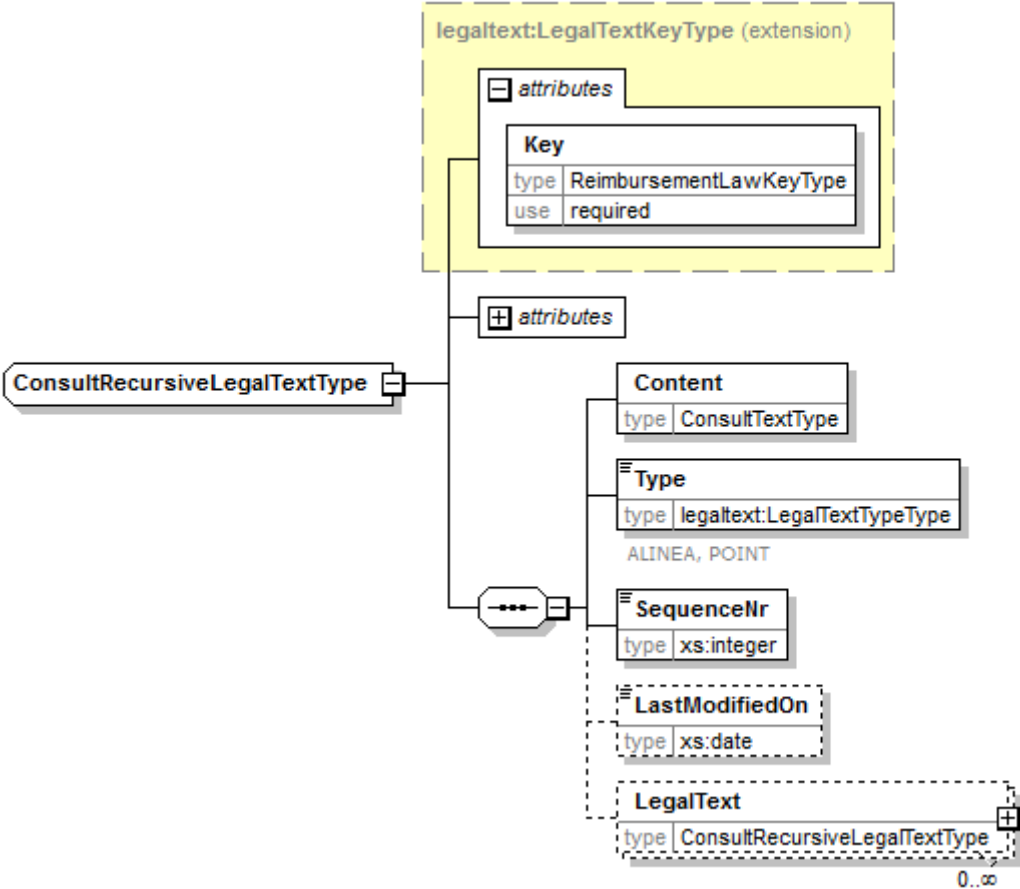

5.5.21 ConsultFormalInterpretationType

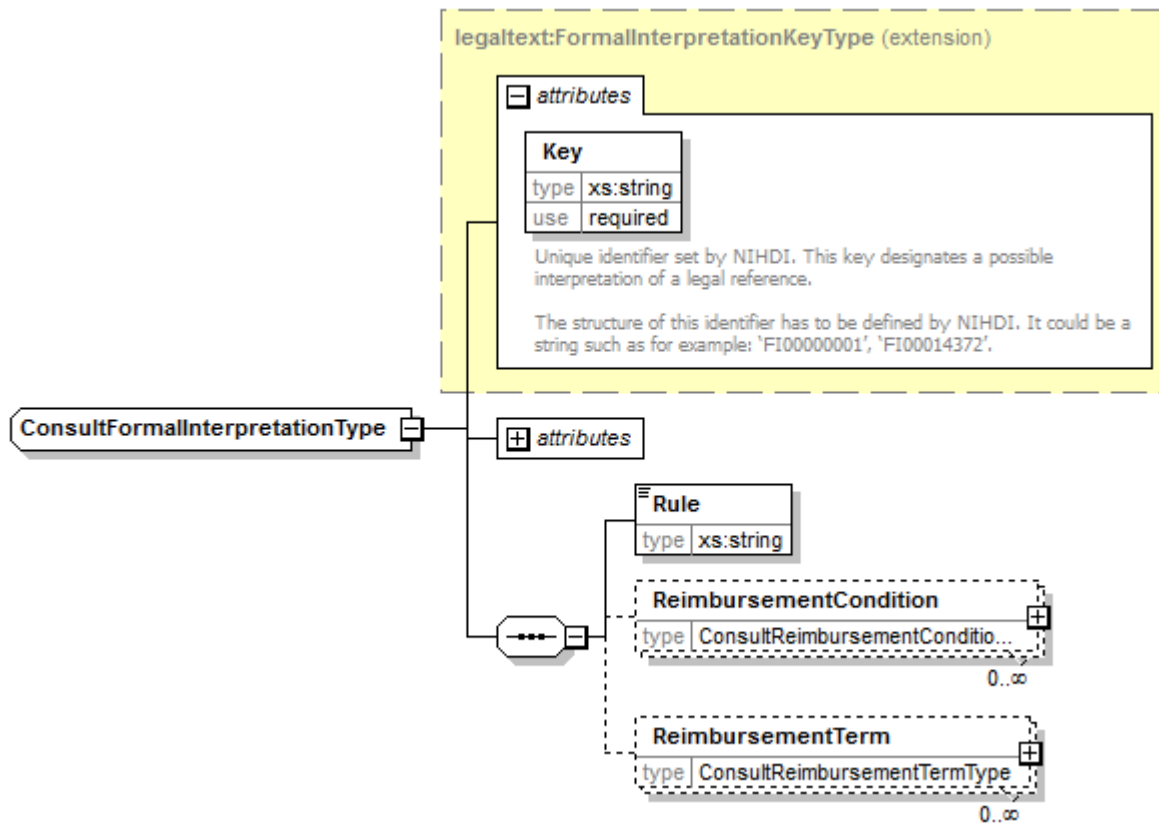

5.5.22 ConsultReimbursementConditionType

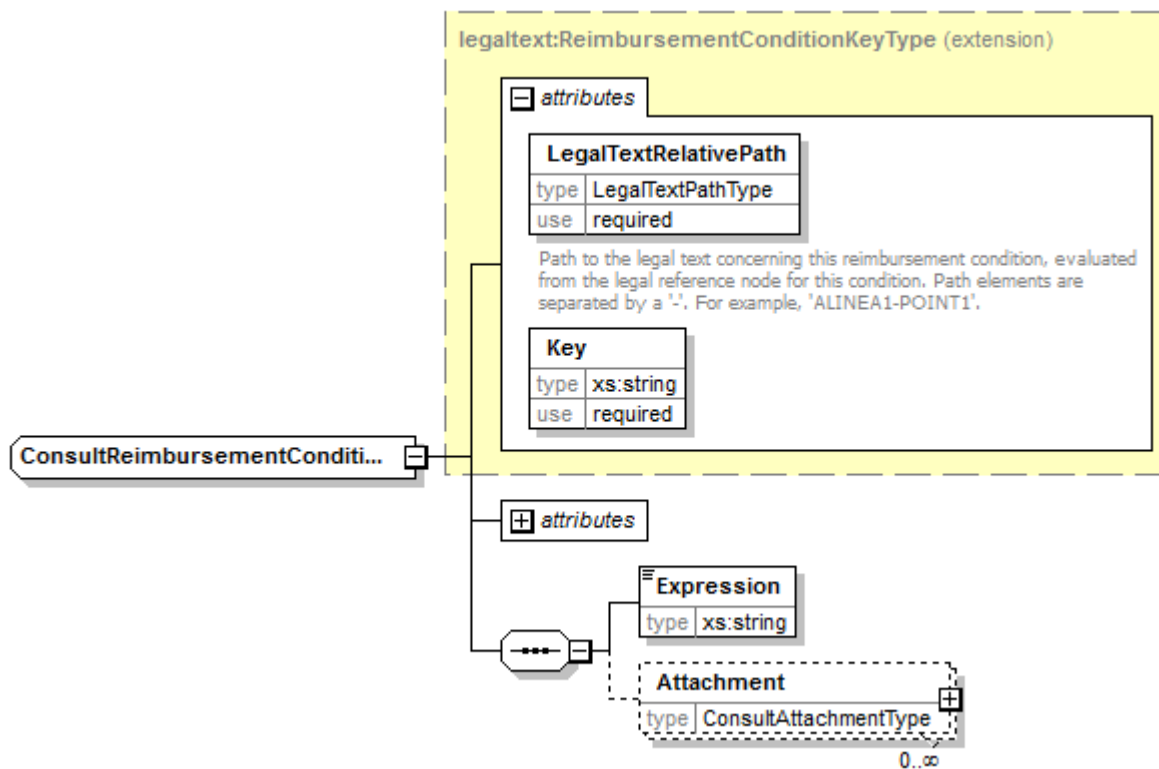

5.5.23 ConsultReimbursementTermType

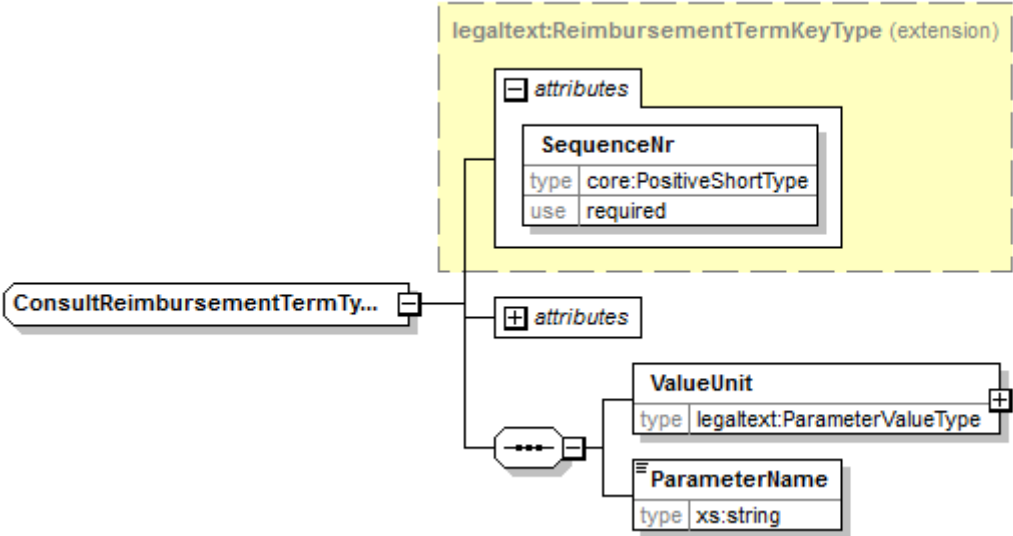

5.5.24 ConsultReimbursementContextType

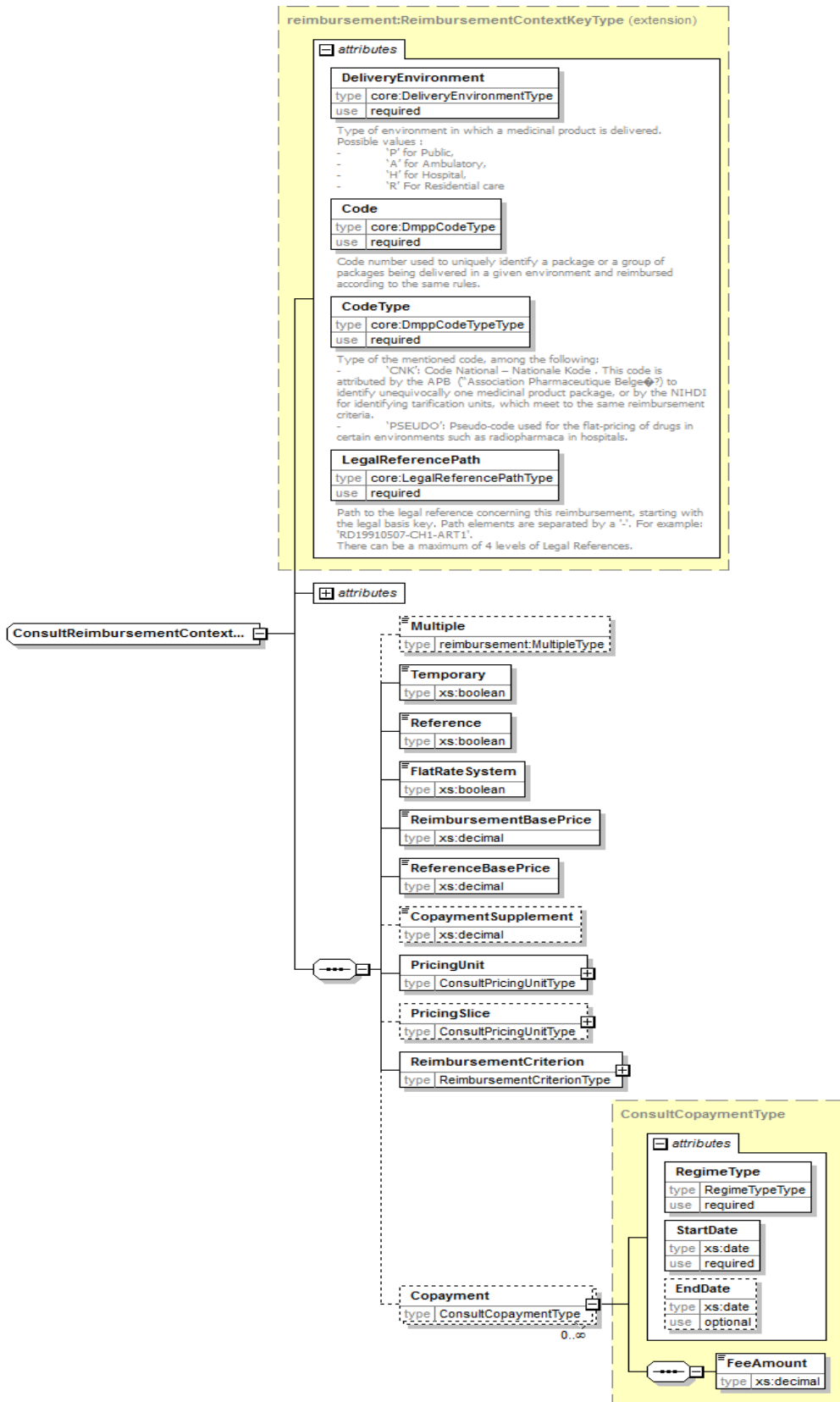

5.5.25 ConsultCompoundingIngredientType

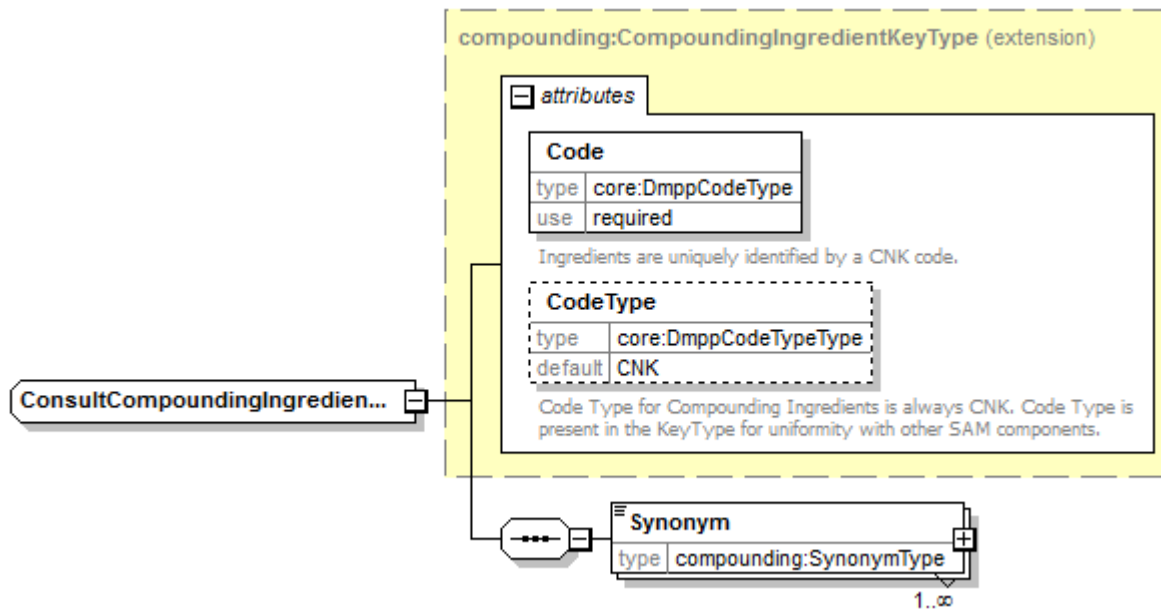

5.5.26 ConsultCompoundingFormulaType

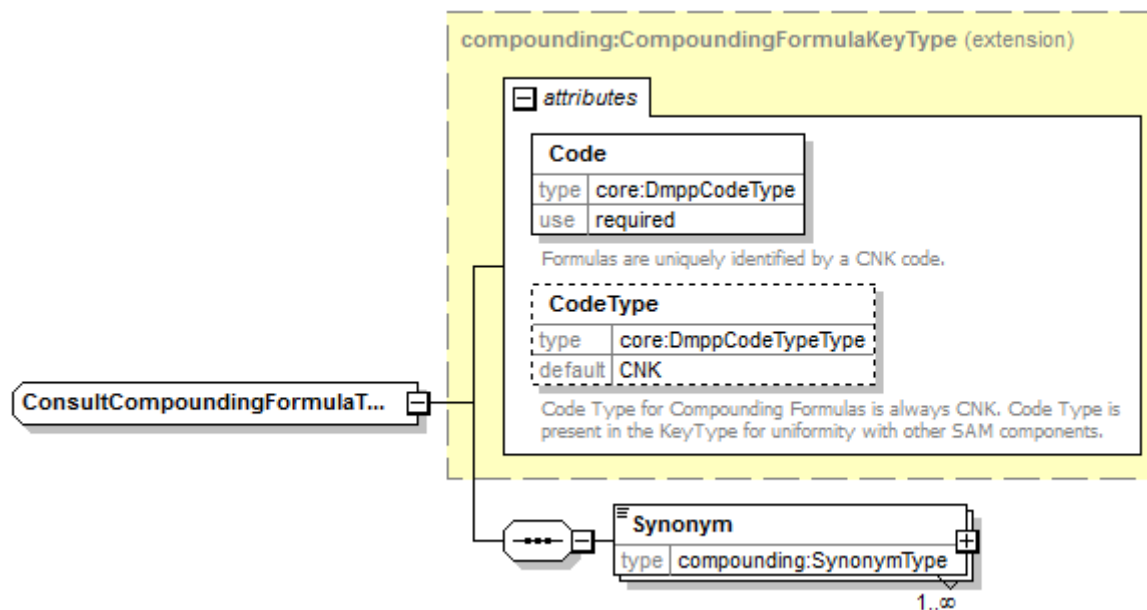

5.5.27 SynonymType

attributes

xml:lang

```

<div>
  <h3>lang (as an attribute name)</h3>
  <p>
    denotes an attribute whose value
    is a language code for the natural language of the content of
    any element; its value is inherited. This name is reserved
    by virtue of its definition in the XML specification.</p>
</div>
<div>
  <h4>Notes</h4>
  <p>
    Attempting to install the relevant ISO 2- and 3-letter
    codes as the enumerated possible values is probably never
    going to be a realistic possibility.
  </p>
  <p>
    See BCP 47 at <a
    href="http://www.rfc-editor.org/rfc/bcp/bcp47.txt">
    http://www.rfc-editor.org/rfc/bcp/bcp47.txt</a>
    and the IANA language subtag registry at
    <a
    href="http://www.iana.org/assignments/language-subtag-registry">
    http://www.iana.org/assignments/language-subtag-registry</a>
    for further information.
  </p>
  <p>
    The union allows for the 'un-declaration' of xml:lang with
    the empty string.
  </p>
</div>

```

Rank

type xs:int

Optional rank of the synonym. Synonyms may be ordered by importance or frequency of use.

SynonymType

Field name	Description
xml:lang	The language of this synonym
Rank	Optional rank of the synonym. Synonyms may be ordered by importance or frequency of use. A smaller number is a higher rank.

5.5.28 ListConsultationResponseType

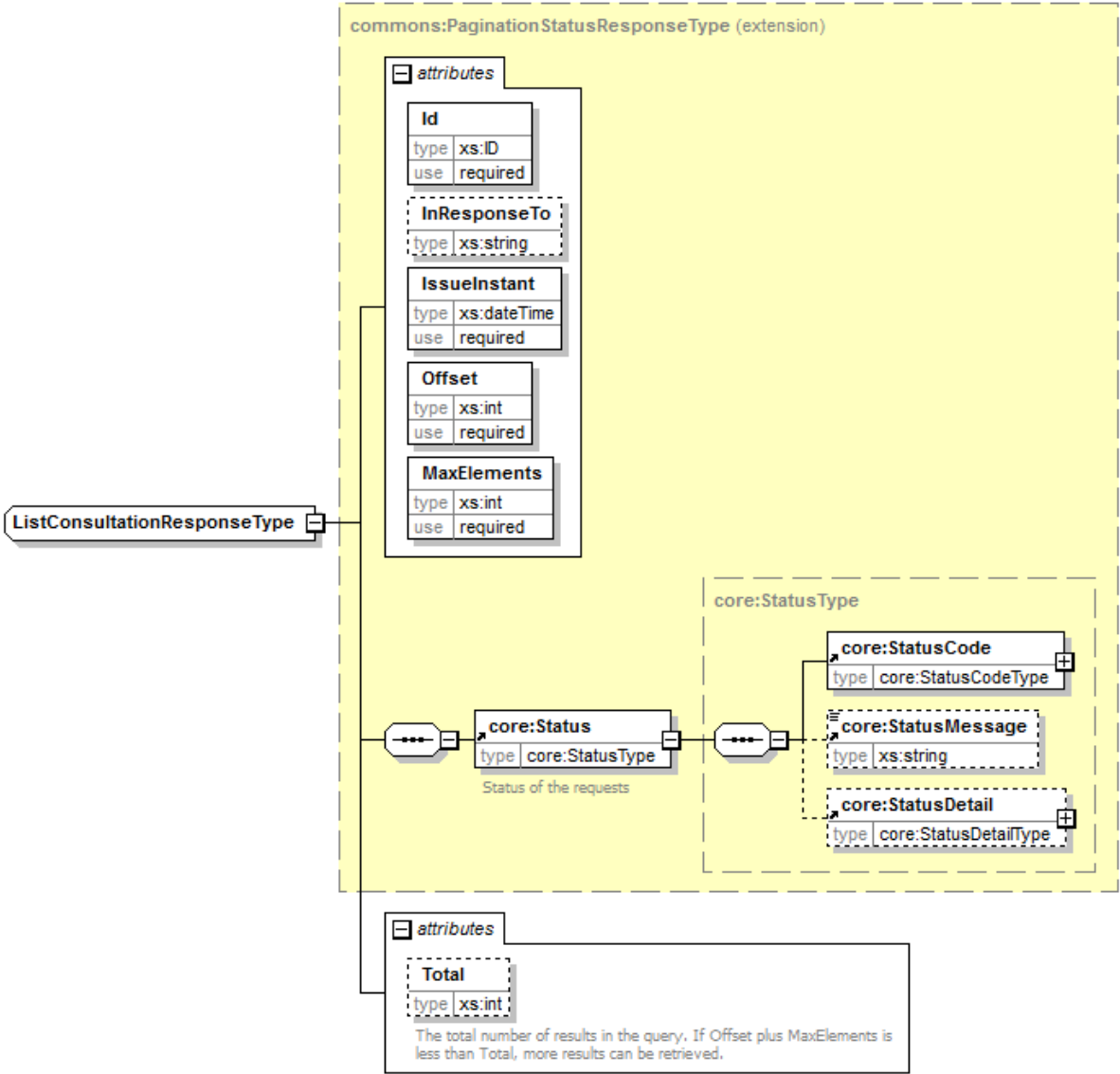

5.5.29 ConsultNonMedicinalProductType

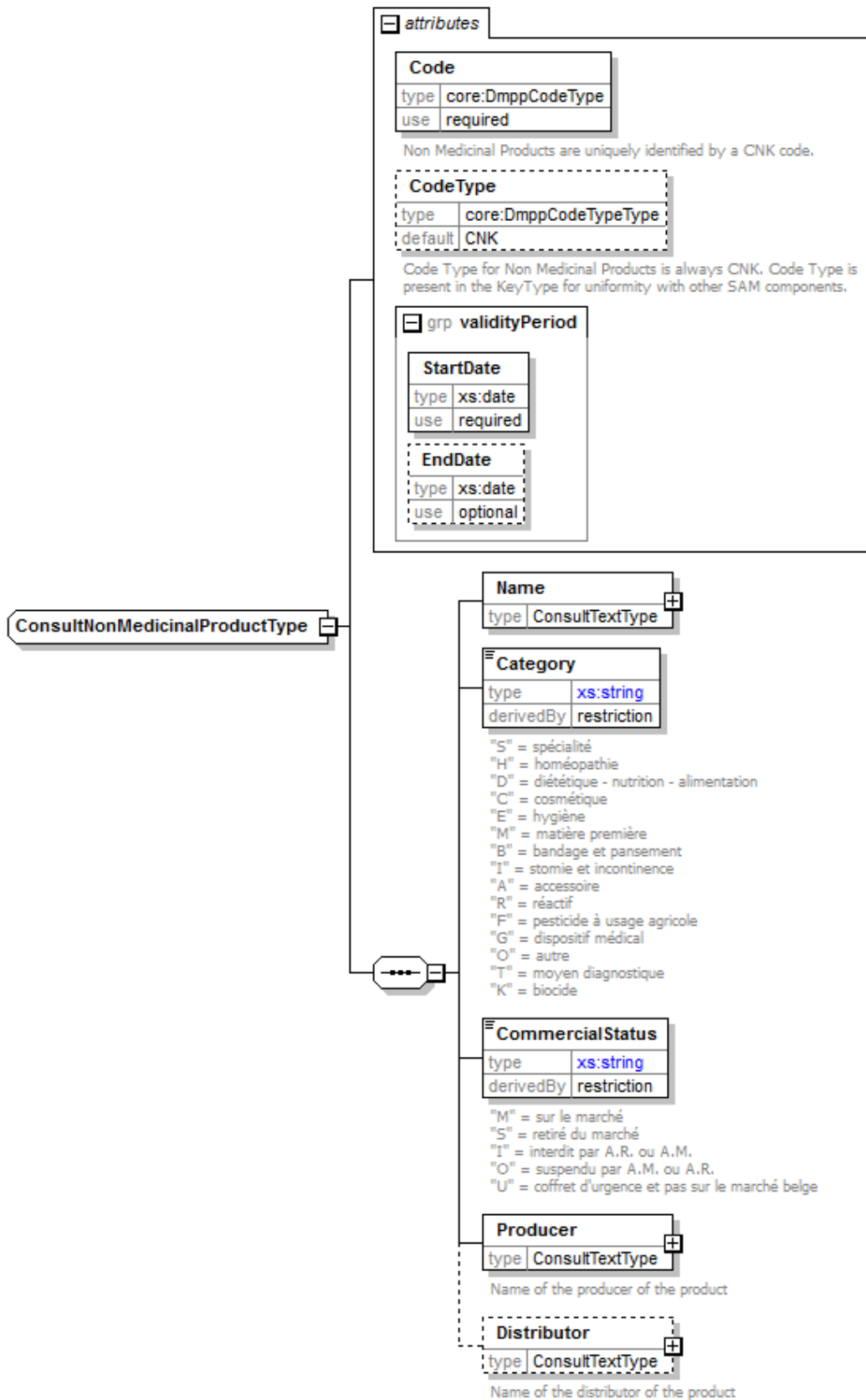

6. Risks and security

6.1 Risks & safety

6.2 Security

6.2.1 Business security

In case the development adds an additional use case based on an existing integration, the eHealth platform must be informed at least one month in advance with a detailed estimate of the expected load. This will ensure an effective capacity management.

In case of technical issues on the WS, the partner may obtain support from the contact center (see Chap 3).

In case the eHealth platform finds a bug or vulnerability in its software, we advise the partner to update his application with the newest version of the software within 10 business days.

In case the partner finds a bug or vulnerability in the software or web service that the eHealth platform delivered, he is obliged to contact and inform us immediately. He is not allowed to publish this bug or vulnerability in any case.

6.2.2 Web service

WS security used in this manner is in accordance with the common standards. Your call will provide:

- SSL one way
- Time-to-live of the message: one minute.
- Signature of the timestamp, body and binary security token. This will allow the eHealth platform to verify the integrity of the message and the identity of the message author.
- No encryption on the message.

6.2.3 The use of username, password and token

The username, password and token are strictly personal. Partners and clients are not allowed to transfer them. Every user takes care of his username, password and token and he is forced to confidentiality of it. Moreover, every user is responsible of every use, which includes the use by a third party, until the inactivation.

7. Test and release procedure

7.1 Procedure

This chapter explains the procedures for testing and releasing an application in acceptance or production.

7.1.1 Initiation

If you intend to use the eHealth platform service, please contact info@ehealth.fgov.be. The project department will provide you with the necessary information and mandatory documents.

7.1.2 Development and test procedure

You have to develop a client in order to connect to our WS. Most of the required integration info is published in on the portal of the eHealth platform.

Upon request, the eHealth platform can provide you with test cases in order for you to test your client before releasing it in the acceptance environment.

7.1.3 Release procedure

When development tests are successful, you can request to access the acceptance environment of the eHealth platform. From this moment, you start the integration and acceptance tests. The eHealth platform suggests testing during minimum one month.

After successful acceptance tests, the partner sends his test results and performance results with a sample of “eHealth request” and “eHealth answer” by email to his point of contact at the eHealth platform.

Then the eHealth platform and the partner agree on a release date. The eHealth platform prepares the connection to the production environment and provides the partner with the necessary information. During the release day, the partner provides the eHealth platform with feedback on the test and performance tests.

For further information and instructions, please contact: integration-support@ehealth.fgov.be.

7.1.4 Operational follow-up

Once in production, the partner using the eHealth platform service for one of his applications will always test first in the acceptance environment before releasing any adaptations of its application in production. In addition, he will inform the eHealth platform on the progress and test period.

7.2 Test cases

No specific test cases have been defined. The test environments contain the same real medicine as the production environment: you can query the database with any existing (approved) medicinal product.

8. Error and failure messages

8.1 Business errors

Business errors are forwarded and mapped to eHealth standard response status.

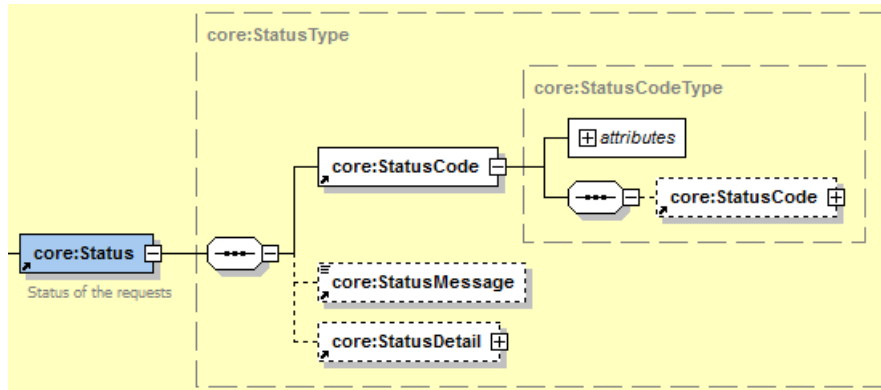

Status codes can be the following:

Status code (lvl 1)	Status code (lvl 2)	Description
urn:be:fgov:ehealth:2.0:status:Success	urn:be:fgov:ehealth:2.0:status:DataNotFound	No data found
urn:be:fgov:ehealth:2.0:status:Requester	urn:be:fgov:ehealth:2.0:status:InvalidInput	Invalid input

Status details come from the SAM v2 services and are displayed as *Anomaly* elements:

AnomalyType

Field name	Required	Description
Code	Yes	(String) SAMv2 Error code.
Description	Yes	Textual description of the error.
TargetObject	Yes	Element of the request's structure where the error is reported.
TargetReference	Yes	Value or element name that can be used to identify on which element the error is reported.

List of codes:

Code	Value
1001	CONSULT_LANG_INCORRECT
1002	CONSULT_AMP_NO_VMP_FOUND
1003	CONSULT_AMP_NO_AMP_FOUND
1004	CONSULT_CPN_NO_CPN_FOUND
1005	CONSULT_VMP_NO_VMP_FOUND
1006	CONSULT_VMP_NO_VMP_GROUP_FOUND
1007	CONSULT_RML_NO_LGT_FOUND

1008	CONSULT_RMB_NO_RMB_FOUND
1009	CONSULT_AMP_REQUIRED_FIND_BY
1010	CONSULT_NO_SEARCH_CRITERIA
1011	CONSULT_VMP_NO_VTM_FOUND
1012	CONSULT_VMP_NO_COM_CLS_FOUND
1013	CONSULT_CMP_NO_INGREDIENT_FOUND
1014	CONSULT_CMP_NO_FORMULA_FOUND
1015	CONSULT_NONMEDICINAL_NO_PRODUCTS_FOUND

Example of a *no data found* business error:

```
<urn:FindCompanyResponse Id="_8671c80f-b769-49d7-856c-b51f54a281e8" IssueInstant="2016-07-28T15:39:35.764+02:00"
InResponseTo="baf225192-1ca1-4402-bd33-9ebb3d978f19" SearchDate="2016-06-27"
xmlns:urn="urn:be:fgov:health:dics:protocol:v2">
  <commonscore:Status xmlns:commonscore="urn:be:fgov:health:commons:core:v2"
xmlns:ehealthns="urn:be:fgov:health:dics:protocol:v2">
    <commonscore:StatusCode Value="urn:be:fgov:health:2.0:status:Success">
      <commonscore:StatusCode Value="urn:be:fgov:health:2.0:status:DataNotFound"/>
    </commonscore:StatusCode>
    <commonscore:StatusDetail>
      <ehealthns:Anomaly>
        <Code>1004</Code>
        <Description>No company found for given criteria.</Description>
        <TargetObject>Consult Company</TargetObject>
        <TargetReference>Consult Company</TargetReference>
      </ehealthns:Anomaly>
    </commonscore:StatusDetail>
  </commonscore:Status>
</urn:FindCompanyResponse>
```

8.2 Technical errors

Technical errors are errors inherent to the internal working of a web service. They are returned as SOAP Faults. Please contact the eHealth platform in case of a technical error.

Description of the possible SOAP fault exceptions

Error code	Component	Description	Solution/Explanation
SOA-00001		Service error	This is the default error sent to the consumer in case further details are unknown.
SOA-01001	Consumer	Service call not authenticated	From the security information provided, <ul style="list-style-type: none"> • or the consumer could not be identified • or the credentials provided are not correct
SOA-01002	Consumer	Service call not authorized	The consumer is identified and authenticated, but is not allowed to call the given service.

SOA-02001	Provider	Service not available. Please contact service desk	An unexpected error has occurred <ul style="list-style-type: none"> • Retries will not work • Service desk may help with root cause analysis
SOA-02002	Provider	Service temporarily not available. Please try later	An unexpected error has occurred <ul style="list-style-type: none"> • Retries should work • If the problem persists service desk may help
SOA-03001	Consumer	Malformed message	This is default error for content related errors in case further details are unknown.
SOA-03002	Consumer	Message must be SOAP	Message does not respect the SOAP standard
SOA-03003	Consumer	Message must contain SOAP body	Message respects the SOAP standard, but body is missing
SOA-03004	Consumer	WS-I compliance failure	Message does not respect the WS-I standard
SOA-03005	Consumer	WSDL compliance failure	Message is not compliant with WSDL in Registry/Repository
SOA-03006	Consumer	XSD compliance failure	Message is not compliant with XSD in Registry/Repository
SOA-03007	Consumer	Message content validation failure	From the message content (conform XSD): <ul style="list-style-type: none"> • Extended checks on the element format failed • Cross-checks between fields failed